

AGRICULTURAL TIRES



Con

03 Size Equivalences

Speed Index 04

05 Load Index Table

Starmaxx AGR Tires by Size 06-08

10-11 Range of Starmaxx
Agricultural Tires

Basic Tire & Rim Terms
Dimensional Definitions
Comparison of Radial and Bias Tire

12

14 Sidewall Marking Radial & Bias Tractor

Tractor Front 16-37

38-57 Tractor Rear



tents

Tractor/Radial-Row Crop 58 - 115

116 -153 Trailer / Implement

Radial Harvester / Harvester 154 -171

172 -185 Flotation & Forestry

Rims 186

189 Valves

Mounting and
Dismounting Instructions
How To Inflate A Tire? 190

191 Storage / Use of Liquid Ballast in Tractor Tyres



Size Equivalences

Rim size diameter	Designation in Inches	85 series	80 series tires	75 series tires	70 series tires	65 series tires	60 series tires	50-55 Series tires	Row Crop Tires 90-95 series
16	-				200/70 R16				
	6.00 R16		210/80 R16		240/70 R16	260/65 R16			
	6.50 R16				260/70 R16	280/65 R16			
	7.50 R16		250/80 R16		280/70 R16	320/64 R16			
18	7.50 R18		250/80 R18		280/70 R18	320/65 R18			
	6.50 R20				260/70 R20				
20	7.50 R20				280/70 R20	340/65 R18			
	9.5 R20		260/80 R20		300/70 R20	340/65 R20			
	11.2 R20	280/85 R20			320/70 R20				
	12.4 R20	320/85 R20	340/80 R20	340/75 R20	360/70 R20	420/65 R20			
	-	250/85 R25			300/70 R24				
	-				380/70 R20				
24	8.3 R24	280/85 R20			320/70 R20				
	9.5 R24	320/85 R20	340/80 R20	340/75 R20	360/70 R20	440/65 R20			
	-	250/85 R24			300/70 R24				
	11.2 R24	280/85 R24			320/70 R24	440/65 R20			
	12.4 R24	320/85 R24			380/70 R24				
	13.6 R24	340/85 R24			360/70 R24	420/65 R24			
	-				380/70 R24	440/65 R24			210/95 R32
	14.9 R24	380/85 R24			400/70 R24				8.3 R32
	-				420/70 R24	480/65 R24			230/95 R32
	16.9 R24	420/85 R24			460/70 R24				9.5 R32
26	14.9 R26				480/70 R24	540/65 R24			270/95 R32
	16.9 R26				380/70 R28	540/65 R24			11.2 R32
	16.9 R26				480/70 R26	540/65 R26			270/95 R36
	-								230/95 R36
	18.4 R26				520/70 R26	540/65 R28	600/60 R28	750/50 R26	11.2 R32
	-				480/70 R28				9.5 R36
	-				580/70 R26				11.2 R36
	23.1 R26			620/75 R26	600/70 R30	600/65 R32		1000/50 R25	270/95 R36
	28 LR26			620/75 R26	650/70 R26	750/65 R26			230/95 R38
	-				600/70 R30	600/65 R32			9.5 R38
28	9.5 R28	250/85 R28			360/70 R24	340/65 R28			
	11.2 R28	280/85 R28			320/70 R28	440/64 R24			210/95 R32
	12.4 R28	320/85 R28			360/70 R28	420/65 R28			8.3 R32
	13.6 R28	340/85 R28			380/70 R28	440/65 R28	480/60 R28		270/95 R32
	14.9 R28	380/85 R28			420/70 R28	480/65 R28	520/60 R28		11.2 R32
	-				480/70 R26	540/65 R26			230/95 R36
	16.9 R28	420/85 R28			480/70 R28	540/65 R28	600/60 R28	750/50 R26	9.5 R36
-				580/70 R26				11.2 R36	
30	14.9 R30	380/85 R30			480/70 R28	540/65 R28			270/95 R36
	16.9 R30	420/85 R30		480/75 R30	480/70 R30	540/65 R30	600/60 R30		11.2 R36
	18.4 R30	460/85 R30			600/65 R28				270/95 R38
	-	320/85 R38			600/65 R30			710/55 R30	11.2 R38
	-				620/70 R26				230/95 R40
	23.1 R30			620/75 R30	600/70 R28	600/65 R30			210/95 R40
32	12.4 R32	320/85 R32			600/70 R28				8.3 R44
	24.5 R32				480/70 R38	540/65 R38	600/60 R38		210/95 R40
	30.5 LR32				650/70 R30				-
	-				650/75 R32				230/95 R38
34	14.9 R34	380/85 R34			680/70 R32	800/60 R32			9.5 R38
	16.9 R34	420/85 R34		400/75 R38	480/70 R34	540/65 R34			11.2 R38
	18.4 R34	460/85 R34		520/75 R34	520/70 R34	600/65 R34			270/95 R44
	-				650/70 R30				11.2 R44
	23.1 R34			620/75 R34	520/70 R38	600/65 R38			230/95 R48
36	-		480/80 R34		650/75 R32				9.5 R48
	8.3 R36	420/85 R24			600/70 R34	540/65 R24			230/95 R44
	11.2 R36	320/85 R34			480/70 R24				270/95 R44
	12.4 R36	320/85 R36		480/75 R30	480/70 R30	540/65 R30	600/60 R30		11.2 R44
	13.6 R36	340/85 R36			520/70 R30	600/65 R30		710/55 R30	11.2 R38
	-	380/85 R34			600/70 R28				210/95 R44
	-	460/85 R30			620/70 R26				8.3 R44
38	12.4 R38	320/85 R38							
	13.6 R38	340/85 R38		400/75 R38	500/70 R34	540/65 R34			230/95 R44
	14.9 R38	380/85 R38	380/80R38	520/75 R34	520/70 R34	600/65 R34			9.5 R44
	-	460/85 R34							230/95 R48
	15.5 R38	340/85 R38		400/75 R38	500/70 R34	540/65 R34			9.5 R48
	16.9 R38	420/85 R38		620/75 R30	480/70 R38	540/65 R38	600/60 R38		230/95 R44
	18.4 R38	460/85 R38	480/80 R38	620/75 R34	520/70 R38	600/65 R38	650/60 R38		300/95 R46
	-			650/75 R32	680/70 R32				12.4 R46
	20.8 R38	520/85 R38	480/80 R42	680/75 R32	580/70 R38	650/65 R38	710/60 R38	900/55 R32	270/95 R48
	-		420/80 R46		620/70 R38	750/65 R34	900/60 R32	1050/50 R32	11.2 R48
42	-				800/65 R32				320/90 R50
	-				600/70 R38				
	18.4 R42	460/85 R42		680/75 R32	580/70 R38	600/65 R42		900/55 R32	320/90 R50
	-	340/85 R48			620/70 R38	650/65 R38		1050/50 R32	
	20.8 R42	520/85 R42	480/80 R46	650/75 R38	580/70 R42	650/65 R42	710/60 R42	900/50 R42	300/95 R52
	-	680/85 R32		710/75 R34	620/70 R42		900/60 R32		12.4 R52
	-				710/70 R38				11.2 R54
46	-		460/80 R42						
	20.8 R46	520/85 R46	480/80 R50		800/70 R38	650/65 R46	900/60 R38		500/95 R32
	-	650/85 R38			710/70 R42				-
2 m 15		460/80 R46			620/70 R46				
		710/85 R38		710/75 R42			900/60 R42		

Tire sizes available in Starmaxx Brand are in bold. The data used in these equivalences chart is based on ETRTO.

** This table is only for reference; our company is not responsible for printing errors.

Speed Index

Speed Index	Speed, km/h
A1	5
A2	10
A3	15
A4	20
A5	25
A6	30
A7	35
A8	40
B	50
C	60
D	65
E	70
F	80
G	90
J	100
K	110
L	120
M	130
N	140
P	150
Q	160
R	170
S	180
T	190
U	200
H	210
V	240
W	270
Y	300

Load Index Table

LI	kg	LI	kg	LI	kg	LI	kg	LI	kg	LI	kg	LI	kg
0	45	40	140	80	450	120	1400	160	4500	200	14000	240	45000
1	46,2	41	145	81	462	121	1450	161	4625	201	14500	241	46250
2	47,5	42	150	82	475	122	1500	162	4750	202	15000	242	47500
3	48,7	43	155	83	487	123	1550	163	4875	203	15500	243	48750
4	50	44	160	84	500	124	1600	164	5000	204	16000	244	50000
5	51,5	45	165	85	515	125	1650	165	5150	205	16500	245	51500
6	53	46	170	86	530	126	1700	166	5300	206	17000	246	53000
7	54,5	47	175	87	545	127	1750	167	5450	207	17500	247	54500
8	56	48	180	88	560	128	1800	168	5600	208	18000	248	56000
9	58	49	185	89	580	129	1850	169	5800	209	18500	249	58000
10	60	50	190	90	600	130	1900	170	6000	210	19000	250	60000
11	61,5	51	195	91	615	131	1950	171	6150	211	19500	251	61500
12	63	52	200	92	630	132	2000	172	6300	212	20000	252	63000
13	65	53	206	93	650	133	2060	173	6500	213	20600	253	65000
14	67	54	212	94	670	134	2120	174	6700	214	21200	254	67000
15	69	55	218	95	690	135	2180	175	6900	215	21800	255	69000
16	71	56	224	96	710	136	2240	176	7100	216	22400	256	71000
17	73	57	230	97	730	137	2300	177	7300	217	23000	257	73000
18	75	58	236	98	750	138	2360	178	7500	218	23600	258	75000
19	77,5	59	243	99	775	139	2430	179	7750	219	24300	259	77500
20	80	60	250	100	800	140	2500	180	8000	220	25000	260	80000
21	82,5	61	257	101	825	141	2575	181	8250	221	25750	261	82500
22	85	62	265	102	850	142	2650	182	8500	222	26500	262	85000
23	87,5	63	272	103	875	143	2725	183	8750	223	27250	263	87500
24	90	64	280	104	900	144	2800	184	9000	224	28000	264	90000
25	92,5	65	290	105	925	145	2900	185	9250	225	29000	265	92500
26	95	66	300	106	950	146	3000	186	9500	226	30000	266	95000
27	97,5	67	307	107	975	147	3075	187	9750	227	30750	267	97500
28	100	68	315	108	1000	148	3150	188	10000	228	31500	268	100000
29	103	69	325	109	1030	149	3250	189	10300	229	32500	269	103000
30	106	70	335	110	1060	150	3350	190	10600	230	33500	270	106000
31	109	71	345	111	1090	151	3450	191	10900	231	34500	271	109000
32	112	72	355	112	1120	152	3550	192	11200	232	35500	272	112000
33	115	73	365	113	1150	153	3650	193	11500	233	36500	273	115000
34	118	74	375	114	1180	154	3750	194	11800	234	37500	274	118000
35	121	75	387	115	1215	155	3875	195	12150	235	38750	275	121000
36	125	76	400	116	1250	156	4000	196	12500	236	40000	276	125000
37	128	77	412	117	1285	157	4125	197	12850	237	41250	277	128500
38	132	78	425	118	1320	158	4250	198	13200	238	42500	278	132000
39	136	79	437	119	1360	159	4375	199	13600	239	43750	279	136000

The load index on the sidewall of the a tire expresses the maximum load that the a tire can bear as kg, the matched figures of each load index, as kg, takes place on the chart.

Starmaxx AGR Tires By Size

TRACTOR FRONT

Profiles / Size	Page
TR-40	
5.50-16	19
6.00-16	19
6.50-16	19
7.50-16	19
6.00-19	19
6.50-20	20
7.50-20	20

TR-20	
6.00-16	23
7.50-16	23
9.00-16	23
11.00-16	23

TR-50	
6.50-16	25
7.50-18	25
7.50-20	25

TR-30	
6.00-16	27
7.50-16	27

TR-25	
6.00-16	29
6.50-16	29
7.50-16	29

TR-35	
10.00-16	31

TR-55	
6.5/80-12	33
6.5/80-13	33

TR-60	
5.00-10	35
5.00-12	35
6.5/80-12	35
7.00-12	35
10.0/80-12	35
5.00-15	35

Profiles / Size	Page
TR-60	
6.5/80-15	35
6.00-16	35
6.50-16	35
7.50-16	36
7.00-18	36
7.50-18	36
7.50-20	36
9.50-20	36

TRACTOR REAR

Profiles / Size	Page
TR-60	
8.3-24	41
9.5-24	41
11.2-24	41
12.4-24	41
13.6-24	41
14.9-24	42
18.4-26	42
11.2-28	42
12.4-28	43
13.6-28	43
14.9-28	43
16.9-28	43
14.9-30	44
16.9-30	44
18.4-30	45
12.4-32	45
16.9-34	46
18.4-34	46
12.4-36	46
13.6-36	47
13.6-38	47
14.00-38	47
15.5-38	48
16.9-38	48
18.4-38	48

Profiles / Size	Page
TR-65	
16.9/14-30	51
TR-300	
9.5-24	53
11.2-24	53
12.4-24	53
13.6-24	53
14.9-24	53
12.4-28	53
13.6-28	53
14.9-28	54
14.9-30	54
16.9-30	54
18.4-30	54
16.9-34	54
18.4-34	54
12.4-36	55
13.6-36	55
16.9-38	55

TR-330	
30.5L32	57

TRACTOR RADIAL ROW CROP

Profiles / Size	Page
Radial TR-110/65	
420/65 R24	61
440/65 R24	61
480/65 R24	61
540/65 R24	62
440/65 R28	62
480/65 R28	62
540/65 R28	62
540/65 R30	63
540/65 R34	63
600/65 R34	63
540/65 R38	64
600/65 R38	64

Profiles / Size	Page
Radial TR-110/70	
200/70 R16	67
240/70 R16	67
260/70 R16	67
280/70 R16	68
280/70 R18	68
260/70 R20	68
280/70 R20	68
300/70 R20	69
320/70 R20	69
360/70 R20	69
380/70 R20	69
320/70 R24	70
360/70 R24	70
380/70 R24	70
420/70 R24	70
480/70 R24	70
480/70 R26	71
320/70 R28	71
360/70 R28	71
380/70 R28	71
420/70 R28	71
480/70 R28	72
420/70 R30	72
480/70 R30	72
520/70 R30	72
480/70 R34	72
520/70 R34	73
480/70 R38	73
520/70 R38	73
580/70 R38	73
580/70 R42	73

Radial TR-110/80	
260/80 R20	75
480/80 R38	75
480/80 R42	75
VF480/80 R42	75
480/80 R46	76
VF480/80 R46	76
480/80 R50	76
VF480/80 R50	77



Profiles / Size	Page
Radial TR-110/85	
9.5 R20	79
9.5 R24	79
280/85 R20	79
320/85 R20	79
280/85 R24	80
320/85 R24	80
340/85 R24	80
380/85 R24	80
420/85 R24	80
280/85 R28	81
320/85 R28	81
340/85 R28	81
380/85 R28	81
420/85 R28	82
380/85 R30	82
420/85 R30	82
460/85 R30	82
320/85 R32	83
380/85 R34	83
420/85 R34	83
460/85 R34	83
320/85 R36	84
340/85 R36	84
320/85 R38	84
340/85 R38	84
380/85 R38	85
420/85 R38	85
460/85 R38	85
460/85 R38 RF	85
520/85 R38	86
520/85 R38 RF	86
520/85 R42	86
520/85 R42 RF	86
VF520/85 R42 RF	87
520/85 R46	87
VF520/85 R46	87

Radial TR-110 PLUS	
650/65 R38	89
650/85 R38	89

Profiles / Size	Page
Radial TR-120 Row Crop	
210/95 R32	91
230/95 R32	91
270/95 R32	92
210/95 R36	92
230/95 R36	92
270/95 R36	93
270/95 R38	93
230/95 R40	94
210/95 R44	94
230/95 R44	94
270/95 R44	95
270/95 R46	
300/95 R46	95
230/95 R48	96
270/95 R48	96
300/95 R52	97
270/95 R54	97
380/90 R46	98
VF380/90 R46	98
340/85 R46	99
340/85 R48	99

Radial TR-130/65	
600/65 R28	101
600/65 R42	101

Radial TR-130/70	
600/70 R28	103
600/70 R30	103
600/70 R34	104
800/70 R38	104
620/70 R42	104

Radial TR-130 PLUS	
710/70 R38	107
710/70 R42	107
VF710/70 R42	107
650/65 R42 (20.8 R42)	108
VF650/65 R42	108
IF710/65 R42	

Radial TR-130 IF SERIES	
IF600/70 R30	111
IF800/70 R38	111

Profiles / Size	Page
S-IRG 80	
14.9/13-24	115
11.2-38	

TRAILER / IMPLEMENT

TR-60 TRAILER	
10.0/75-15.3	119
11.5/80-15.3	119

Radial VF HST-70	
VF285/70 R19.5	121

RM-50	
9.00-16	122
11.5/80-15.3	122

RM-80	
9.00-16	125

RM-60	
8.25-20	127

RM-70	
9.00-20	129

SM-270	
7.50-16	131

SM-160	
7.50-16	133

IMP-80	
19.0/45-17	
500/50-17	
15.0/55-17	
340/55-16	
400/60-15.5	
13.0/65-18	
10.0/75-15.3	
12.5/80-18	
10.5/80-18	
12.5/80-15.3	
11.5/80-15.3	

Profiles / Size	Page
IMP-90	
11.5/80-15.3 RF	139
12.5/80-15.3 RF	139
10.0/75-15.3 RF	139
260/70-15.3	139

IMP-100	
10.0/80-12	141

IMP-110	
9.5L-14SL	143
9.5L-15SL	143
11L-15SL	143
12.5L-15SL	143

IMP-70 TRAILER	
16.0/70-20	145
400/70-20	145

IMP-60	
500/50-17	147

SR-3	
10.0/75-15.3	149

SM-350	
7.50-16	151

RF: REINFORCED
 IF: IMPROVED FLEXION
 VF: VERY HIGH FLEXION

Starmaxx AGR Tires By Size

HARVESTER RADIAL / HARVESTER

Profiles / Size	Page	Profiles / Size	Page
TR-130 AGROVEST		TR-330	
620/75 R26	155	30.5L-32	167
620/75 R30	155	IMP-80 HARVESTER	
650/75 R32	156	12.5/80-18	169
800/65 R32	157		
SB-140 AGROVEST			
400/70 R20	159		
IMP-70 HARVESTER			
16.0/70-20	161		
400/70-20	161		
TR-90			
18.4-30	163		
TR-95			
23.1-26	165		
23.1-30	165		
20.8-38	165		

FORESTRY - FLOTATION

Profiles / Size	Page	Profiles / Size	Page
SM-F18		ST-HAUL	
12.5/80-15.3	173	560/60 R22.5	181
12.5/80-15.3 RF	173	SM-T08	
400/60-15.5	173	500/60-22.5	183
500/60-22.5	173	550/60-22.5	183
550/60-22.5	173	600/50-22.5	183
600/50-22.5	173	SM-T18	
ST-FLOT		400/60-15.5	175
560/60 R22.5	177	500/60-22.5	175
600/55 R26.5	178	550/60-22.5	175
650/55 R26.5	178	600/50-22.5	175
710/50 R26.5	179		
560/45 R22.5			

RF: REINFORCED
 IF: IMPROVED FLEXION
 VF: VERY HIGH FLEXION

Starmaxx Agricultural Tires: Offer Unique Tread Designs



RANGE OF STARMAXX AGRICULTURAL TIRES

• TRACTOR FRONT



• TRACTOR REAR



• TRACTOR RADIAL



Radial

Radial

Row Crop

Radial

Radial

• IRRIGATION

• TRAILER / IMPLEMENT



Radial

Radial

• TRAILER / IMPLEMENT



RM-80

RM-60

RM-70

SM-270

SM-160

IMP-80

Trailer



IMP-40

IMP-90

IMP-100

IMP-110

IMP-70

Trailer

• HARVESTER RADIAL/HARVESTER



IMP-60

SR-3

SM-350

TR-130
AGROVEST

SB-140
AGROVEST

Radial

Radial



IMP-70

TR-90

TR-95

TR-330

IMP-80

Harvester

Harvester

Harvester

Harvester

Harvester

• FORESTRY - FLOTATION



SM-F18

ST-FLOT

ST-HAUL

SM-T08

SMT-18

BASIC TIRE & RIM TERMS

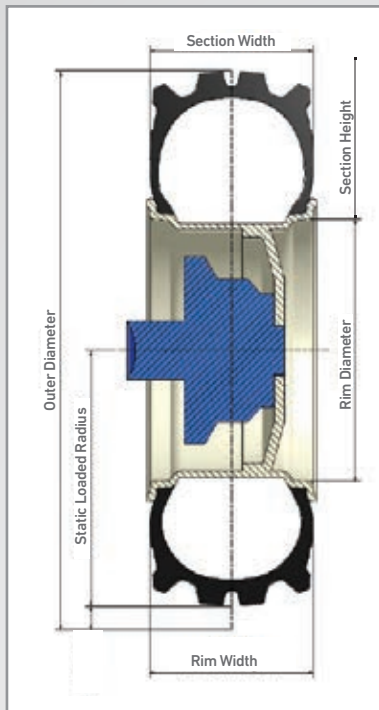

Outer Diameter: The diameter of the inflated tire on recommended rim without any load.

Section Width: The widest distance between the outside sidewalls of an inflated tire without any load.

Section Height: The distance from rim seat to the outer tread surface of an unloaded tire.

Static Loaded Radius: The height between axle center and road surface of the tire under load.

Rim Width: The distance between flanges of the rim.

Rim Diameter: The vertical distance between the bead seat areas of the rim.

Dynamic Rolling Circumference: The distance of the tire at one rotation.

RADIAL AND BIAS TRACTOR TIRES



Radial tire construction:
The cords are placed towards the tire center with 90 degrees.



Bias tire construction:
the cords are placed diagonally with certain degrees for the rotation direction of a tire.

THE ADVANTAGES OF A RADIAL TIRE

- Better grip and traction with wide tread, reduced slip
- Lower rolling resistance
- Minimized soil compaction
- Maximized life span
- Improved driving comfort with stronger and more flexible sidewall
- Lower fuel consumption
- Higher load capacity

The plies wrap the tire with an angle lower than 90° from bead to bead. Each ply or carcass cord take place in a bias position.

The plies wrap the tire with an angle of 90° from bead to bead. In addition to parallel body plies, there are also bias impact plies.



Starmaxx Agricultural Tires:
Designed for Power.

SIDEWALL MARKING

a) Radial Tractor

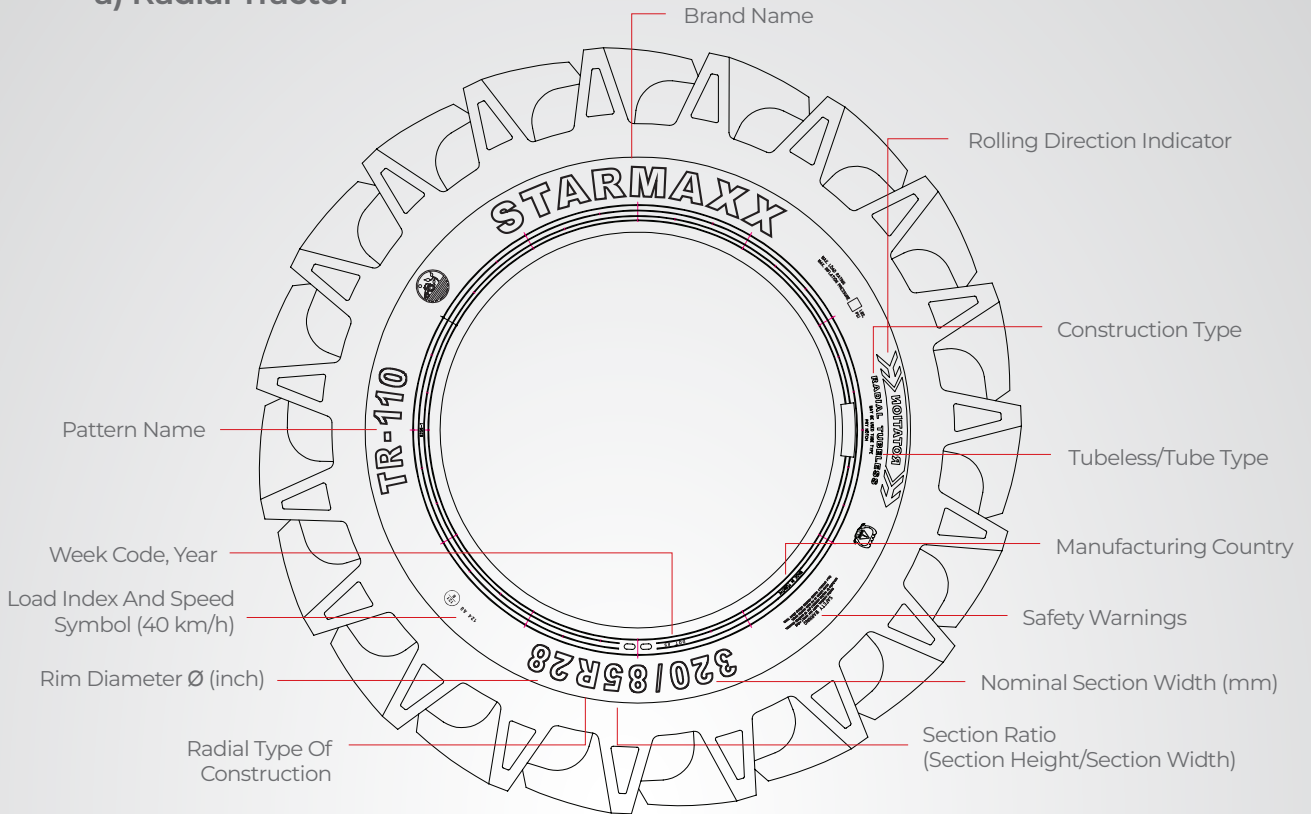

b) Bias Tractor

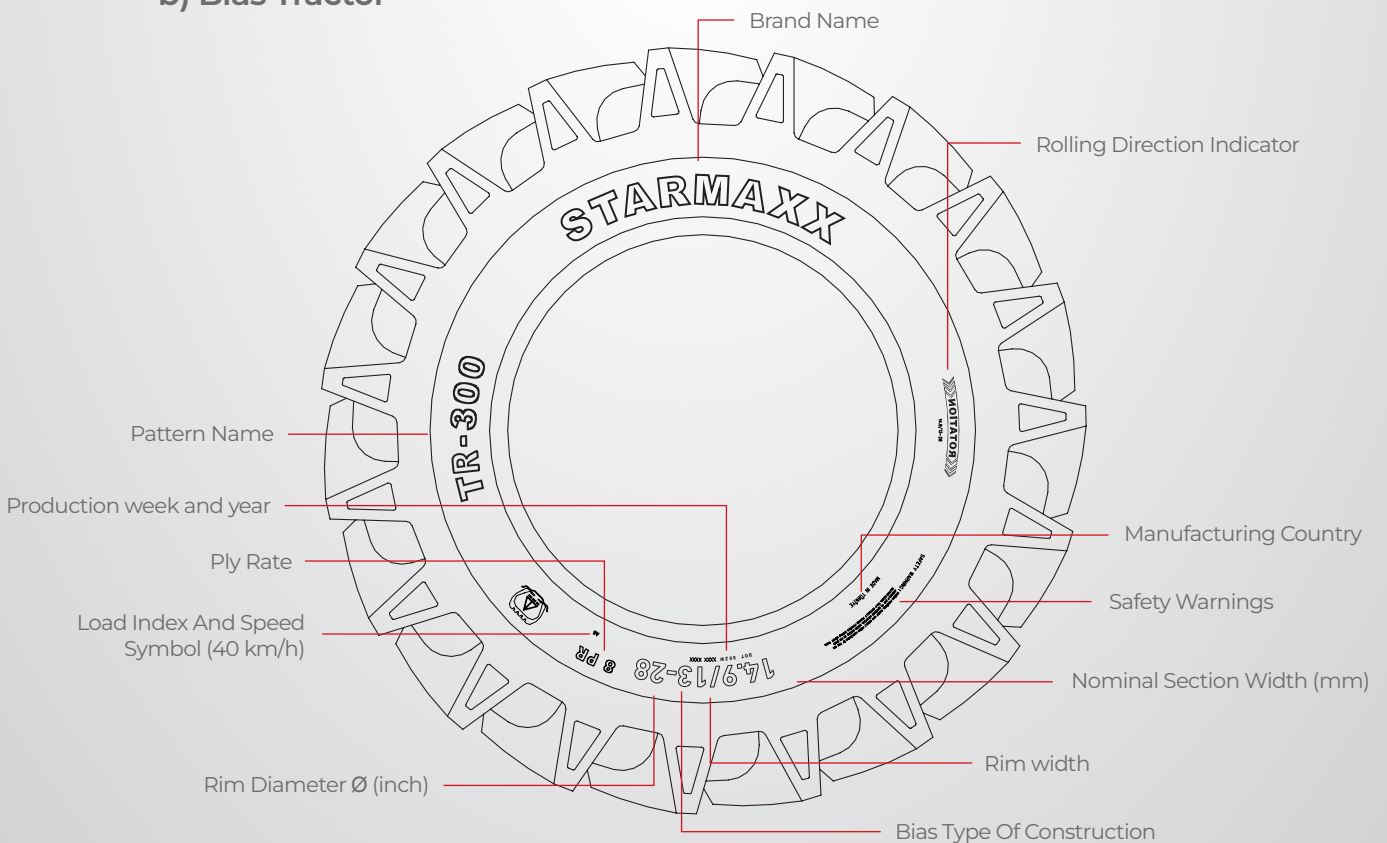

Starmaxx Agricultural Tires:

High Quality Tires for Tillage Operations.



Tractor Front

TR-40
TR-20
TR-50
TR-30
TR-25
TR-35
TR-55
TR-60



TR-40

TR-20

TR-50

TR-30

TR-25

TR-35

TR-55

TR-60



TR-40 Tractor Front

PERFORMANCE INFORMATION

Front tire for 2WD tractors appropriate for using on field and short distance road operations.



FEATURES

Long service life / Durability

Offers long life thanks to its wear-resistant tread compound.

Durable shoulders protect the tire effectively by increasing its resistance to any kind of damage.

Ease of use

Special tread design keeps the tread free of mud.

SIZES

5.50-16 • 6.00-16 • 6.50-16 • 7.50-16 • 6.00-19 • 6.50-20 • 7.50-20

Tractor Front · Characteristics of **TR-40**

Tire Size	PR	TT/TL	Load/Speed Index	Rims		Inflated Dimensions (No Load)		Inflated Dimensions (W/Load)		Inflation Pressure (psi/bar)	Load capacity per tire, kg					
				Recom (inch)	Permitted (inch)	Section Width (mm)	Outer Diameter (mm)	Dynamic Rolling Circumference (mm)	Static Loaded Radius (mm)		Speed, km/h					
											10	15	20	25	30	40
5.50-16	6	TT	86/A6	4.00E	3.50D, 4.50E	150	710	2130	329	45/3.1	745	710	670	570	495	395
										49/3.4	775	735	695	595	515	415
										54/3.7	795	760	715	610	530	425
6.00-16	6	TT	88/A6	4.50E	4.00E, 5.00F	165	735	2205	338	41/2.8	775	735	695	595	515	410
										45/3.1	825	790	745	635	550	440
										48/3.3	840	800	755	645	560	450
6.50-16	6	TT	91/A6	4.50E	4.00E, 5K, 5.50F, 5.50F	175	760	2280	350	38/2.6	850	810	765	650	565	450
										42/2.9	915	875	825	705	610	485
										45/3.1	925	880	830	710	615	495
	52/3.6	1005	960							905	770	670	535			
	8	TT	97/A6							57/3.9	1050	1000	945	805	700	560
										61/4.2	1095	1045	985	840	730	585
35/2.4				1050	1000	945	805	700	560							
7.50-16	6	TT	98/A6	5.50F	5.00F, 5K, 6.00F	205	805	2415	367	38/2.6	1095	1045	985	840	730	585
										41/2.8	1125	1075	1015	865	750	600
										45/3.1	1210	1150	1085	925	805	645
	8	TT	103/A6							49/3.4	1275	1215	1150	980	850	680
										54/3.7	1315	1250	1180	1005	875	700
										41/2.8	900	860	810	690	600	480
6.00-19	6	TT	93/A6	4.50E	4.00E, 5.00F	165	814	2442	378	45/3.1	955	910	860	730	635	510
										48/3.3	975	930	880	750	650	520

Load capacity on recommended speed and pressure is stated with dark colour.

DESCRIPTION

* For load capacity on various speed ratings, and inflation figures, please consult your sales representative.

** Load capacity on standard speed and weight

- Our company is entitled to make any change on any information in this catalogue, without further notice.
- This catalogue annuls all the previous catalogues
- All figures are for reference; our company is not responsible for printing errors.

Tractor Front • Characteristics of **TR-40**

Tire Size	PR	TT/TL	Load/Speed Index	Rims		Inflated Dimensions (No Load)		Inflated Dimensions (W/Load)		Inflation Pressure (psi/bar)	Load capacity per tire, kg					
				Recom (inch)	Permitted (inch)	Section Width (mm)	Outer Diameter (mm)	Dynamic Rolling Circumference (mm)	Static Loaded Radius (mm)		Speed, km/h					
											10	15	20	25	30	40
6.50-20	8	TT	108/A6	5.00F	4.00E, 5.50F	165	865	2595	402	45/3,1	1395	1330	1255	1070	930	745
										49/3,4	1455	1385	1310	1115	970	775
										54/3,7	1500	1430	1350	1150	1000	800
	10	TT	115/A6							54/3,7	1660	1580	1490	1270	1155	885
										58/4,0	1730	1650	1560	1325	1185	925
										62/4,3	1820	1735	1640	1400	1215	970
7.50-20	8	TT	108/A6	5.50F	5.00F	214	915	2727	420	42/2,9	1380	1315	1245	1060	920	735
										45/3,1	1440	1375	1295	1105	960	770
										49/3,4	1500	1430	1350	1150	1000	800
	10	TT	115/A6							49/3,4	1660	1580	1490	1270	1105	885
										54/3,7	1730	1650	1560	1325	1155	925
										58/4,0	1820	1735	1640	1400	1215	970

Load capacity on recommended speed and pressure is stated with dark colour.

DESCRIPTION

* For load capacity on various speed ratings, and inflation figures, please consult your sales representative.

** Load capacity on standard speed and weight

- Our company is entitled to make any change on any information in this catalogue, without further notice.
- This catalogue annuls all the previous catalogues
- All figures are for reference; our company is not responsible for printing errors.

Starmaxx Agricultural Tires:

Footprint of Your Confidence.



TR-20 Tractor Front

PERFORMANCE INFORMATION

Ideal 2WD tractor front tire with special 3Rib design.



FEATURES

Long service life / Durability

The rib design provides ultimate steering performance during soil tillage operations and on soft and cultivated areas.

Specially formulated tread compound and all steel carcass structure offer longevity.

Ease of use

Flexible carcass structure prevents sinking.

Self-cleaning

Special tread design provides efficient self-cleaning feature.

SIZES 6.00-16 • 7.50-16 • 9.00-16 • 11.00-16

Tractor Front · Characteristics of **TR-20**

Tire Size	PR	TT/TL	Load/Speed Index	Rims		Inflated Dimensions (No Load)		Inflated Dimensions (W/Load)		Inflation Pressure (psi/bar)	Load capacity per tire, kg					
				Recom (inch)	Permitted (inch)	Section Width (mm)	Outer Diameter (mm)	Dynamic Rolling Circumference (mm)	Static Loaded Radius (mm)		Speed, km/h					
											10	15	20	25	30	40
6.00-16	6	TT	88/A6	4.50E	4.00E, 5.00F	165	735	2205	338	41/2.8	805	765	725	615	535	430
										45/3.1	825	785	745	635	550	440
										48/3.3	840	800	755	645	560	450
7.50-16	8	TT	103/A6	5.50F	5.00F, 5K, 6.00F	205	805	2415	367	45/3.1	1200	1144	1080	920	800	640
										49/3.4	1245	1190	1120	955	830	665
										54/3.7	1315	1250	1180	1005	875	700
9.00-16	8	TT	111/A6	W8	6.00F, W7, W8L	234	855	2556	392	38/2.6	1495	1425	1345	1145	995	795
										42/2.9	1565	1495	1410	1205	1045	835
										45/3.1	1635	1560	1475	1255	1090	875
11.00-16	8	TT	118/A6	WW10L	W8, W8L	315	965	2876	437	30/2.1	1845	1760	1660	1415	1230	985
										33/2.3	1900	1810	1710	1455	1265	1015
										36/2.5	1980	1890	1780	1520	1320	1055

Load capacity on recommended speed and pressure is stated with dark colour.

DESCRIPTION

- * For load capacity on various speed ratings, and inflation figures, please consult your sales representative.
- ** Load capacity on standard speed and weight

- Our company is entitled to make any change on any information in this catalogue, without further notice.
- This catalogue annuls all the previous catalogues
- All figures are for reference; our company is not responsible for printing errors.

TR-50

Tractor Front

PERFORMANCE INFORMATION

Front tire for 2WD tractors suitable to be used on field and short distance road operations.



FEATURES

Long service life / Durability

Improved tread compound enable high resistance against wears and cuts.

Strong center and shoulder design improves durability towards side impacts and tread base fatigue.

Ease of use

Tread pattern and flexible carcass structure provide excellent maneuverability without sinking into the soil.

Special tread geometry provides easy steering.

SIZES 6.50-16 · 7.50-18 · 7.50-20

Tractor Front · Characteristics of **TR-50**

Tire Size	PR	TT/TL	Load/Speed Index	Rims		Inflated Dimensions (No Load)		Inflated Dimensions (W/Load)		Inflation Pressure (psi/bar)	Load capacity per tire, kg					
				Recom (inch)	Permitted (inch)	Section Width (mm)	Outer Diameter (mm)	Dynamic Rolling Circumference (mm)	Static Loaded Radius (mm)		Speed, km/h					
											10	15	20	25	30	40
6.50-16	6	TT	91/A6	4.50E	4.00E, 5K, 5.50F, 5.50F	175	760	2280	350	38/2.6	840	800	755	645	560	450
										41/2.8	890	845	800	680	590	475
										45/3.1	925	880	830	705	615	495
	8	TT	97/A6							52/3.6	1015	965	910	775	675	540
										57/3.9	1050	1000	945	805	700	560
										61/4.2	1095	1045	985	840	730	585
7.50-18	8	TT	106/A6	5.50F	-	205	860	2580	396	45/3.1	1325	1265	1195	1020	885	708
										49/3.4	1390	1325	1250	1065	925	740
										54/3.7	1425	1360	1285	1095	950	760
7.50-20	8	TT	108/A6	5.50F	5.00F	205	915	2727	420	42/2.9	1380	1315	1245	1060	920	735
										45/3.1	1440	1375	1295	1105	960	770
										49/3.4	1500	1430	1350	1150	1000	800

Load capacity on recommended speed and pressure is stated with dark colour.

DESCRIPTION

- * For load capacity on various speed ratings, and inflation figures, please consult your sales representative.
- ** Load capacity on standard speed and weight

- Our company is entitled to make any change on any information in this catalogue, without further notice.
- This catalogue annuls all the previous catalogues
- All figures are for reference; our company is not responsible for printing errors.

TR-30 Tractor Front

PERFORMANCE INFORMATION

Front tire for 2WD tractors suitable to be used on field and short distance road operations.



FEATURES

Long service life / Durability

Improved tread compound enable high resistance against wears and cuts.

Strong center and shoulder design provides high resistance to side impacts and tread base fatigue.

Ease of use

Tread pattern and flexible carcass structure provide excellent maneuverability without sinking into the soil.

Special tread geometry provides easy steering.

SIZES 6.00-16 · 7.50-16

Tractor Front · Characteristics of **TR-30**

Tire Size	PR	TT/TL	Load/Speed Index	Rims		Inflated Dimensions (No Load)		Inflated Dimensions (W/Load)		Inflation Pressure (psi/bar)	Load capacity per tire, kg					
				Recom (inch)	Permitted (inch)	Section Width (mm)	Outer Diameter (mm)	Dynamic Rolling Circumference (mm)	Static Loaded Radius (mm)		Speed, km/h					
											10	15	20	25	30	40
6.00-16	6	TT	88 / A6	4.50E	4.00E, 5.00F	165	735	2205	338	41 / 2.8	775	735	695	595	515	415
										45 / 3.1	825	790	745	635	550	440
										48 / 3.3	840	800	755	645	560	450
7.50-16	8	TT	103 / A6	5.50F	5.00F, 5K, 6.00F	205	805	2407	367	45 / 3.1	1195	1140	1075	915	795	635
										49 / 3.4	1245	1190	1120	955	830	665
										54 / 3.7	1315	1250	1180	1005	875	700

Load capacity on recommended speed and pressure is stated with dark colour.

DESCRIPTION

- * For load capacity on various speed ratings, and inflation figures, please consult your sales representative.
- ** Load capacity on standard speed and weight

- Our company is entitled to make any change on any information in this catalogue, without further notice.
- This catalogue annuls all the previous catalogues
- All figures are for reference; our company is not responsible for printing errors.

TR-25

Tractor Front

PERFORMANCE INFORMATION

Front tire for 2WD tractors suitable to be used on field and short distance road operations.



FEATURES

Long service life / Durability

Solid tread center structure and strong nylon carcass enhances durability.

Durable shoulders protect the tire effectively by increasing its resistance to any kind of damage.

Ease of use

The strong and flexible carcass structure that prevents sinking into the soil also ensures long life.

SIZES 6.00-16 • 6.50-16 • 7.50-16

Tractor Front · Characteristics of **TR-25**

Tire Size	PR	TT/TL	Load/Speed Index	Rims		Inflated Dimensions (No Load)		Inflated Dimensions (W/Load)		Inflation Pressure (psi/bar)	Load capacity per tire, kg					
				Recom (inch)	Permitted (inch)	Section Width (mm)	Outer Diameter (mm)	Dynamic Rolling Circumference (mm)	Static Loaded Radius (mm)		Speed, km/h					
											10	15	20	25	30	40
6.00-16	6	TT	88/A6	4.50E	4.00E, 5.00F	165	735	2205	338	41/2.8	795	760	715	610	530	425
										45/3.1	825	790	745	635	550	440
										48/3.3	840	800	755	645	560	450
	10	TT	98/A6							68/4.7	1070	1020	960	820	710	570
										73/5.0	1100	1050	990	845	735	590
80/5.5	1125	1070	1010	860	750	600										
6.50-16	6	TT	91/A6	4.50E	4.00E, 5K, 5.50F, 5.50F	175	760	2280	350	39/2.7	855	815	770	655	570	460
										42/2.9	885	845	800	680	590	470
										45/3.1	920	880	830	705	615	495
	8	TT	97/A6							52/3.6	1015	965	910	775	675	540
										57/3.9	1050	1000	945	805	700	560
										61/4.2	1095	1045	985	840	730	585
7.50-16	8	TT	103/A6	5.50F	5.00F, 5K, 6.00F	205	805	2407	367	45/3.1	1195	1135	1075	915	795	635
										49/3.4	1245	1185	1120	955	830	665
										54/3.7	1315	1250	1180	1005	875	700

Load capacity on recommended speed and pressure is stated with dark colour.

DESCRIPTION

- * For load capacity on various speed ratings, and inflation figures, please consult your sales representative.
- ** Load capacity on standard speed and weight

- Our company is entitled to make any change on any information in this catalogue, without further notice.
- This catalogue annuls all the previous catalogues
- All figures are for reference; our company is not responsible for printing errors.



TR-35 Tractor Front

PERFORMANCE INFORMATION

Ideal 2WD tractor front tire with special 3Rib design.



FEATURES

Long service life / Durability

The rib design provides ultimate steering performance during soil tillage operations and on soft and cultivated areas.

Specially formulated tread compound and all steel carcass structure offer longevity.

Ease of use

Flexible carcass structure prevents sinking into the soil.

Self-cleaning

Special tread design provides efficient self-cleaning feature.

SIZE 10.00-16

Tractor Front · Characteristics of **TR-35**

Tire Size	PR	TT/TL	Load/Speed Index	Rims		Inflated Dimensions (No Load)		Inflated Dimensions (W/Load)		Inflation Pressure (psi/bar)	Load capacity per tire, kg					
				Recom (inch)	Permitted (inch)	Section Width (mm)	Outer Diameter (mm)	Dynamic Rolling Circumference (mm)	Static Loaded Radius (mm)		Speed, km/h					
											10	15	20	25	30	40
10.00-16	8	TT	114/A6	W8	W8L	274	895	2667	404	35/2.4	1645	1565	1480	1260	1095	875
										38/2.6	1715	1635	1545	1315	1145	915
										41/2.8	1770	1685	1595	1355	1180	945

Load capacity on recommended speed and pressure is stated with dark colour.

DESCRIPTION

* For load capacity on various speed ratings, and inflation figures, please consult your sales representative.

** Load capacity on standard speed and weight

- Our company is entitled to make any change on any information in this catalogue, without further notice.
- This catalogue annuls all the previous catalogues
- All figures are for reference; our company is not responsible for printing errors.

TR-55

Tractor Front

PERFORMANCE INFORMATION

High traction R-1 tractor front tire for medium and low powered tractors.



FEATURES

Long service life / Durability

Highly resistant to cuts and wears.
Tread profile provides outstanding durability to tread base fatigue.

High traction / Self-cleaning

Wide and strong body provides easy grip and high traction.

Offers effective self-cleaning feature and grip performance during tillage operations by its special tread geometry.

SIZES 6.5/80-12 · 6.5/80-13

Tractor Front · Characteristics of **TR-55**

Tire Size	PR	TT/TL	Load/Speed Index	Rims		Inflated Dimensions (No Load)		Inflated Dimensions (W/Load)		Inflation Pressure (psi/bar)	Load capacity per tire, kg					
				Recom (inch)	Permitted (inch)	Section Width (mm)	Outer Diameter (mm)	Dynamic Rolling Circumference (mm)	Static Loaded Radius (mm)		Speed, km/h					
											10	15	20	25	30	40
6.5/80-12	6	TL	80/A6	5J	5JA	170	630	1735	275	44 / 3.0	625	595	560	480	415	335
										48 / 3.3	655	625	590	500	435	350
										52 / 3.6	675	645	610	520	450	360
6.5/80-13	6	TT	94/A6	5J	5JA	171	642	1765	280	44 / 3,0	930	890	840	715	620	500
										48 / 3,3	975	920	875	745	645	515
										52 / 3,6	1005	960	905	770	670	535

Load capacity on recommended speed and pressure is stated with dark colour.

DESCRIPTION

* For load capacity on various speed ratings, and inflation figures, please consult your sales representative.

** Load capacity on standard speed and weight

- Our company is entitled to make any change on any information in this catalogue, without further notice.
- This catalogue annuls all the previous catalogues
- All figures are for reference; our company is not responsible for printing errors.

TR-60 Tractor Front

PERFORMANCE INFORMATION

High traction R-1 tractor front tire for medium and low powered tractors.



FEATURES

Long service life / Durability

Offers long service life thanks to its wear-resistant tread compound.

Tread profile enable high resistance to tread base fatigue.

High traction / Self-cleaning

The wide and long lugs provide comfortable drive while improving grip performance.

Wide and strong body provides ultimate grip and high traction.

Special tread geometry provides efficient self-cleaning feature.

SIZES

5.00-10 · 5.00-12 · 6.5/80-12 · 7.00-12 · 10.0/80-12 · 5.00-15 · 6.5/80-15 · 6.00-16 · 6.50-16
7.50-16 · 7.00-18 · 7.50-18 · 7.50-20 · 9.50-20

Tractor Front · Characteristics of **TR-60**

Tire Size	PR	TT/TL	Load/Speed Index	Rims		Inflated Dimensions (No Load)		Inflated Dimensions (W/Load)		Inflation Pressure (psi/bar)	Load capacity per tire, kg					
				Recomd (inch)	Permitted (inch)	Section Width (mm)	Outer Diameter (mm)	Dynamic Rolling Circumference (mm)	Static Loaded Radius (mm)		Speed, km/h					
											10	15	20	25	30	40
5.00-10	4	TT	70-58/A6	4J	3.5B	140	512	1526	241	25/1.7	475	450	425	360	315	250
										26/1.8	485	460	435	370	322	260
										29/2.0	505	480	450	385	335	270
5.00-12	4	TT	62/A6	3.50D	3.00D, 4.00E, 4J	145	567	1690	267	56/1.8	370	350	330	285	245	195
										57/2.0	385	365	345	293	255	205
										58/2.3	400	380	360	305	265	215
6.5/80-12	6	TT	80/A6	5J	5JA	163	569	1707	270	44/3.0	625	595	560	480	415	335
										45/3.3	655	625	590	500	435	350
										46/3.6	675	645	610	520	450	360
7.00-12	6	TT	83/A6	4,25	-	200	667	1988	301	47/2.1	685	650	615	525	455	365
										48/2.3	705	675	635	540	470	375
										49/2.5	730	700	660	560	487	390
10.0/80-12	6	TT	98/A6	9.00	7.00	264	730	2175	327	50/1.9	1060	1010	950	810	705	565
										51/2.1	1095	1045	985	840	730	585
										52/2.3	1125	1075	1015	865	750	600
10.0/80-12	6	TL	98/A6	9.00	7.00	264	730	2175	327	50/1.9	1060	1010	950	810	705	565
										51/2.1	1095	1045	985	840	730	585
										52/2.3	1125	1075	1015	865	750	600
5.00-15	6	TT	88/A6	4.00E	3.00D, 4J, 4 1/2	144	655	1952	305	53/3.0	780	745	705	600	520	415
										54/3.2	810	775	730	620	540	430
										55/3.5	840	800	755	645	560	450
6.5/80-15	6	TT	98/A6	5J	4 1/2 K, 5 K	163	663	1976	303	44/3.0	945	900	850	720	630	505
										48/3.3	1010	960	910	775	675	540
										52/3.6	1125	1070	1010	860	750	600
6.00-16	6	TT	88/A6	4.50E	4.00E, 5K, 5.00F	165	735	2190	340	62/2.8	775	735	695	595	515	415
										63/3.1	810	775	730	620	540	435
										64/3.3	840	800	755	645	560	450

Load capacity on recommended speed and pressure is stated with dark colour.

DESCRIPTION

- * For load capacity on various speed ratings, and inflation figures, please consult your sales representative.
- ** Load capacity on standard speed and weight

- Our company is entitled to make any change on any information in this catalogue, without further notice.
- This catalogue annuls all the previous catalogues
- All figures are for reference; our company is not responsible for printing errors.

Tractor Front · Characteristics of **TR-60**

Tire Size	PR	TT/TL	Load/Speed Index	Rims		Inflated Dimensions (No Load)		Inflated Dimensions (W/Load)		Inflation Pressure (psi/bar)	Load capacity per tire, kg					
				Recom (inch)	Permitted (inch)	Section Width (mm)	Outer Diameter (mm)	Dynamic Rolling Circumference (mm)	Static Loaded Radius (mm)		Speed, km/h					
											10	15	20	25	30	40
6.50-16	6	TT	91/A6	4.50E	4.00E, 5K, 5.00F, 5.50F	175	760	2265	348	65/2.7	865	825	775	660	575	460
										66/2.9	885	845	800	680	590	475
										67/3.1	925	880	830	705	615	495
7.50-16	8	TT	103/A6	5.50F	5.00F, 5K, 6.00F	205	805	2399	367	68/3.1	1225	1165	1100	940	815	655
										69/3.4	1275	1215	1150	980	850	680
										70/3.7	1315	1250	1180	1005	875	700
7.00-18	8	TT	106/A6	5.50F	5.00F	178	803	2425	375	71/2.3	1315	1250	1180	1005	875	700
										72/2.5	1375	1310	1235	1055	915	735
										73/2.7	1425	1360	1285	1095	950	760
7.50-18	8	TT	106/A6	5.50F	-	205	860	2563	398	74/3.1	1330	1265	1195	1020	885	710
										75/3.4	1390	1325	1250	1065	925	740
										76/3.7	1425	1360	1285	1095	950	760
7.50-20	8	TT	108/A6	5.50F	5.00F	205	915	2727	421	77/2.9	1380	1315	1245	1060	920	735
										78/3.1	1440	1375	1300	1105	960	770
										79/3.4	1500	1430	1350	1150	1000	800
9.50-20	8	TT	107/A6	W8	W7	241	945	2816	459	80/2.3	1350	1290	1215	1035	900	720
										81/2.5	1410	1345	1270	1080	940	750
										82/2.8	1465	1395	1315	1120	975	780

Load capacity on recommended speed and pressure is stated with dark colour.

DESCRIPTION

- * For load capacity on various speed ratings, and inflation figures, please consult your sales representative.
- ** Load capacity on standard speed and weight

- Our company is entitled to make any change on any information in this catalogue, without further notice.
- This catalogue annuls all the previous catalogues
- All figures are for reference; our company is not responsible for printing errors.

Starmaxx Agricultural Tires:

Strong, Durable Tires for Professionals.





Tractor Rear

TR-60

TR-65

TR-300

TR-330

TR-60

TR-65

TR-300

TR-330



TR-60 Tractor Rear

PERFORMANCE INFORMATION

High traction R-1 tractor rear tire for medium and low powered tractors.



FEATURES

Long service life / Durability

Offers long service life thanks to its wear-resistant tread compound.

Tread profile enable high resistance to tread base fatigue.

High traction / Self-cleaning

The wide and long lugs provide comfortable drive while improving grip performance.

Wide and strong body provides ultimate grip and high traction.

Special tread geometry provides efficient self-cleaning feature.

SIZES

8.3-24 · 9.5-24 · 11.2-24 · 12.4-24 · 13.6-24 · 14.9-24 · 18.4-26 · 11.2-28 · 12.4-28 · 13.6-28 · 14.9-28
16.9-28 · 14.9-30 · 16.9-30 · 18.4-30 · 12.4-32 · 16.9-34 · 18.4-34 · 12.4-36 · 13.6-36 · 13.6-38
14.00-38 · 15.5-38 · 16.9-38 · 18.4-38

Tractor Rear · Characteristics of **TR-60**

Tire Size	PR	TT/TL	Load/Speed Index	Rims		Inflated Dimensions (No Load)		Inflated Dimensions (W/Load)		Inflation Pressure (psi/bar)	Load capacity per tire, kg					
				Recom (inch)	Permitted (inch)	Section Width (mm)	Outer Diameter (mm)	Dynamic Rolling Circumference (mm)	Static Loaded Radius (mm)		Speed, km/h					
											10	15	20	25	30	40
8.3-24	8	TT	108/A6	W7	W6	211	995	2965	455	39 / 2.7	1275	1185	1090	975	910	820
										42 / 2.9	1315	1220	1130	1005	940	845
										46 / 3.2	1400	1300	1200	1070	1000	900
9.5-24	8	TT	112/A6	W8	W7	241	1050	3129	481	33 / 2.3	1430	1325	1225	1090	1020	920
										36 / 2.5	1490	1385	1280	1140	1065	960
										41 / 2.8	1570	1455	1345	1200	1120	1010
11.2-24	8	TT	116/A6	W10	W9	284	1105	3293	503	29 / 2.0	1630	1515	1400	1245	1165	1050
										32 / 2.2	1680	1560	1440	1285	1200	1080
										35 / 2.4	1750	1625	1500	1340	1250	1125
12.4-24	6	TT	115 / A6	W11	W9, W10	315	1160	3457	525	20 / 1.4	1545	1435	1325	1180	1105	995
										22 / 1.5	1615	1500	1385	1235	1155	1040
										25 / 1.7	1700	1580	1460	1300	1215	1095
	8	TT	120 / A6							29 / 2.0	1860	1730	1595	1425	1330	1200
										32 / 2.2	1920	1780	1645	1465	1370	1235
										33 / 2.3	1960	1820	1680	1500	1400	1260
										44 / 3.0	2345	2180	2010	1790	1675	1510
										46 / 3.2	2420	2250	2075	1850	1730	1560
12	TT	128 / A6	51 / 3.5	2520	2340	2160	1925	1800	1620							
			25 / 1.7	2045	1900	1750	1560	1460	1315							
13.6-24	8	TT	123/A6	DW12	DW11	345	1200	3576	541	28 / 1.9	2085	1940	1790	1595	1490	1340
										29 / 2.0	2170	2015	1860	1660	1550	1395

Load capacity on recommended speed and pressure is stated with dark colour.

DESCRIPTION

* For load capacity on various speed ratings, and inflation figures, please consult your sales representative.

** Load capacity on standard speed and weight

- Our company is entitled to make any change on any information in this catalogue, without further notice.
- This catalogue annuls all the previous catalogues
- All figures are for reference; our company is not responsible for printing errors.

Tractor Rear · Characteristics of **TR-60**

Tire Size	PR	TT/TL	Load/Speed Index	Rims		Inflated Dimensions (No Load)		Inflated Dimensions (W/Load)		Inflation Pressure (psi/bar)	Load capacity per tire, kg					
				Recom (inch)	Permitted (inch)	Section Width (mm)	Outer Diameter (mm)	Dynamic Rolling Circumference (mm)	Static Loaded Radius (mm)		Speed, km/h					
											10	15	20	25	30	40
14.9-24	4	TL	112/A6	W13	W11, W12	378	1265	3770	567	-	-	-	-	-	-	-
										10/0.7	1490	1385	1280	1140	1065	960
	12/0.8	1570	1455							1345	1200	1120	1010			
	-	-	-							-	-	-	-			
	4	TT	112/A6							10/0.7	1490	1385	1280	1140	1065	960
										12/0.8	1570	1455	1345	1200	1120	1010
	6	TT	123/A6							15/1.0	1780	1650	1525	1360	1270	1145
										17/1.2	1975	1835	1690	151	1410	1270
	6	TT	123/A6							20/1.4	2170	2015	1860	1660	1550	1395
										22/1.5	2395	2225	2050	1830	1710	1540
	8	TT	128/A6							23/1.6	2445	2270	2095	1865	1745	1570
										26/1.8	2520	2340	2160	1925	1800	1620
	10	TT	134/A6							29/2.0	2820	2620	2420	2155	2015	1815
										32/2.2	2910	2705	2495	2225	2080	1870
10	TT	134/A6	33/2.3	2970	2755	2545	2270	2120	1910							
			39/2.7	3375	3135	2890	2580	2410	2170							
14	TT	142/A6	43/3.0	3560	3310	3055	2725	2545	2290							
			46/3.2	3710	3445	3180	2835	2650	2385							
14	TL	142/A6	39/2.7	3375	3135	2890	2580	2410	2170							
			43/3.0	3560	3310	3055	2725	2545	2290							
			46/3.2	3710	3445	3180	2835	2650	2385							
11.2-28	8	TT	118/A6	W10	W9	284	1205	3591	554	29/2.0	1720	1600	1475	1315	1230	1110
										32/2.2	1780	1650	1525	1360	1270	1145
										35/2.4	1850	1715	1585	1410	1320	1190
18.4-26	14	TT	146/A6	W16L	W15L	467	1450	4321	647	35/2.4	4230	3925	3625	3230	3020	2720
										38/2.6	4415	4100	3785	3375	3155	2840
	41/2.8	4550	4225							3900	3480	3250	2925			
	12	TT	149/A6							29/2.0	3990	3705	3420	3050	2850	2565
										32/2.2	4115	3820	3530	3145	2940	2645
	12	TT	149/A6							33/2.3	4200	3900	3600	3210	3000	2700
										29/2.0	3990	3705	3420	3050	2850	2565
	12	TL	149/A6							32/2.2	4115	3820	3530	3145	2940	2645
33/2.3				4200	3900	3600	3210	3000	2700							

Load capacity on recommended speed and pressure is stated with dark colour.

Tractor Rear · Characteristics of **TR-60**

Tire Size	PR	TT/TL	Load/Speed Index	Rims		Inflated Dimensions (No Load)		Inflated Dimensions (W/Load)		Inflation Pressure (psi/bar)	Load capacity per tire, kg					
				Recom (inch)	Permitted (inch)	Section Width (mm)	Outer Diameter (mm)	Dynamic Rolling Circumference (mm)	Static Loaded Radius (mm)		Speed, km/h					
											10	15	20	25	30	40
12.4-28	6	TT	117/A6	W11	W9, W10	315	1260	3755	576	20/1.4	1640	1520	1405	1250	1170	1055
										22/1.5	1710	1585	1465	1305	1220	1100
										25/1.7	1800	1670	1540	1375	1285	1160
	8	TT	122/A6							29/2.0	1995	1855	1710	1525	1425	1283
										32/2.2	2060	1910	1765	1575	1470	1323
										33/2.3	2100	1950	1800	1605	1500	1350
13.6-28	6	TT	121/A6	W12	W11	345	1310	3904	596	20/1.4	1845	1715	1585	1410	1320	1190
										22/1.5	1955	1815	1675	1490	1395	1255
										23/1.6	2030	1885	1740	1550	1450	1305
	8	TT	125/A6							25/1.7	2170	2015	1860	1660	1550	1395
										28/1.9	2270	2105	1945	1735	1620	1460
										29/2.0	2310	2145	1980	1765	1650	1485
14.9-28	6	TT	125/A6	W13	W11, W12	378	1365	4068	618	17/1.2	2105	1955	1805	1610	1505	1355
										19/1.3	2200	2040	1885	1680	1570	1415
										20/1.4	2310	2145	1980	1765	1650	1485
	8	TT	130/A6							22/1.5	2480	2300	2125	1895	1770	1595
										23/1.6	2610	2425	2240	1995	1865	1680
										26/1.8	2660	2470	2280	2035	1900	1710
16.9-28	8	TT	135/A6	W15L	W14L	429	1435	4276	646	20/1.4	2780	2580	2380	2125	1985	1790
										22/1.5	2900	2690	2485	2215	2070	1865
										25/1.7	3050	2835	2615	2335	2180	1965
	10	TT	139/A6							25/1.7	3200	2970	2740	2445	2285	2055
										26/1.8	3270	3035	2800	2500	2335	2100
										29/2.0	3400	3160	2915	2600	2430	2190
										29/2,0	3585	3330	3070	2740	2560	2305
										32/2,2	3700	3440	3175	2830	2645	2375
										35/2,4	3815	3545	3270	2915	2725	2450
14	TT	143/A8														

Load capacity on recommended speed and pressure is stated with dark colour.

Tractor Rear · Characteristics of **TR-60**

Tire Size	PR	TT/TL	Load/Speed Index	Rims		Inflated Dimensions (No Load)		Inflated Dimensions (W/Load)		Inflation Pressure (psi/bar)	Load capacity per tire, kg					
				Recom (inch)	Permitted (inch)	Section Width (mm)	Outer Diameter (mm)	Dynamic Rolling Circumference (mm)	Static Loaded Radius (mm)		Speed, km/h					
											10	15	20	25	30	40
14.9-30	8	TT	131/A6	W13	W11, W12	378	1415	4217	643	22/1.5	2541	2360	2180	1940	1815	1635
										23/1.6	2674	2483	2290	2045	1910	1720
										26/1.8	2730	2535	2340	2085	1950	1755
	10	TT	135/A6							29/2.0	2900	2690	2485	2215	2070	1865
	32/2.2									2990	2775	2560	2285	2135	1925	
	33/2.3									3050	2835	2615	2335	2180	1965	
16.9-30	8	TT	137/A6	W15L	W14L	429	1485	4425	671	20/1.4	2935	2725	2515	2240	2095	1885
										22/1.5	3060	2840	2620	2340	2185	1970
										25/1.7	3220	2990	2760	2460	2300	2070
	10	TT	139/A6							26/1.8	3200	2970	2740	2445	2285	2060
										28/1.9	3340	3095	2855	2545	2380	2145
										29/2.0	3400	3160	2915	2600	2430	2190
	12	TT	143/A6							29/2.0	3550	3295	3040	2710	2535	2285
										32/2.2	3660	3400	3140	2800	2615	2355
										35/2.4	3815	3545	3270	2915	2725	2455
	14	TT	144/A6							32/2.2	3645	3390	3125	2790	2605	2345
										35/2.4	3765	3500	3230	2880	2690	2420
										38/2.6	3920	3640	3360	2995	2800	2520

Load capacity on recommended speed and pressure is stated with dark colour.

DESCRIPTION

- * For load capacity on various speed ratings, and inflation figures, please consult your sales representative.
- ** Load capacity on standard speed and weight

- Our company is entitled to make any change on any information in this catalogue, without further notice.
- This catalogue annuls all the previous catalogues
- All figures are for reference; our company is not responsible for printing errors.

Tractor Rear · Characteristics of **TR-60**

Tire Size	PR	TT/TL	Load/Speed Index	Rims		Inflated Dimensions (No Load)		Inflated Dimensions (W/Load)		Inflation Pressure (psi/bar)	Load capacity per tire, kg					
				Recom (inch)	Permitted (inch)	Section Width (mm)	Outer Diameter (mm)	Dynamic Rolling Circumference (mm)	Static Loaded Radius (mm)		Speed, km/h					
											10	15	20	25	30	40
18.4-30	6	TT	134 / A6	W16L	W15L	467	1550	4619	697	13 / 0.9	2700	2510	2315	2065	1930	1740
										15 / 1.0	2820	2620	2420	2155	2015	1815
										16 / 1.1	2970	2755	2545	2270	2120	1910
	8	TT	139 / A6							17 / 1.2	3095	2875	2650	2365	2210	1990
										19 / 1.3	3235	3000	2770	2470	2310	2080
										20 / 1.4	3400	3160	2915	2600	2430	2190
	10	TT	145 / A6							22 / 1.5	3780	3510	3240	2890	2700	2430
										23 / 1.6	3985	3700	3415	3045	2845	2560
										26 / 1.8	4060	3770	3480	3100	2900	2610
										29 / 2.0	4325	4015	3710	3305	3090	2780
										32 / 2.2	4415	4100	3785	3375	3155	2840
										33 / 2.3	4550	4225	3900	3480	3250	2925
										33 / 2.3	4445	4130	3810	3400	3175	2860
										36 / 2.5	4641	4310	3980	3545	3315	2985
39 / 2.7	4830	4485	4140	3690	3450	3105										
12	TT	149 / A6	33 / 2.3	4445	4130	3810	3400	3175	2860							
			36 / 2.5	4641	4310	3980	3545	3315	2985							
			39 / 2.7	4830	4485	4140	3690	3450	3105							
14	TT	151 / A6	33 / 2.3	4445	4130	3810	3400	3175	2860							
			36 / 2.5	4641	4310	3980	3545	3315	2985							
			39 / 2.7	4830	4485	4140	3690	3450	3105							
			42 / 2.8	5025	4670	4320	3840	3570	3195							
12.4-32	8	TT	124 / A6	W11	W9, W10	315	1360	4053	626	29 / 2.0	2130	1975	1825	1625	1520	1370
										32 / 2.2	2200	2040	1885	1680	1570	1415
										33 / 2.3	2240	2080	1920	1710	1600	1440

Load capacity on recommended speed and pressure is stated with dark colour.

DESCRIPTION

- * For load capacity on various speed ratings, and inflation figures, please consult your sales representative.
- ** Load capacity on standard speed and weight

- Our company is entitled to make any change on any information in this catalogue, without further notice.
- This catalogue annuls all the previous catalogues
- All figures are for reference; our company is not responsible for printing errors.

Tractor Rear · Characteristics of **TR-60**

Tire Size	PR	TT/TL	Load/Speed Index	Rims		Inflated Dimensions (No Load)		Inflated Dimensions (W/Load)		Inflation Pressure (psi/bar)	Load capacity per tire, kg					
				Recom (inch)	Permitted (inch)	Section Width (mm)	Outer Diameter (mm)	Dynamic Rolling Circumference (mm)	Static Loaded Radius (mm)		Speed, km/h					
											10	15	20	25	30	40
16.9-34	8	TT	139/A6	W15L	W14L	429	1585	4723	721	20/1.4	3095	2875	2650	2365	2210	1990
										22/1.5	3235	3000	2770	2470	2310	2080
										25/1.7	3400	3160	2915	2600	2430	2190
	25/1.7	3380	3140							2900	2585	2415	2175			
	26/1.8	3530	3275							3025	2700	2520	2270			
	29/2.0	3710	3445							3180	2835	2650	2385			
	29/2.0	3860	3580							3305	2950	2755	2480			
	32/2.2	3980	3700							3415	3045	2845	2560			
	33/2.3	4060	3770							3480	3100	2900	2610			
	29/2.0	3705	3440							3175	2830	2650	2380			
33/2.3	4100	3810	3515	3135	2930	2640										
38/2.6	4410	4095	3780	3370	3150	2835										
18.4-34	8	TT	141/A6	W16L	W15L	467	1650	4917	747	17/1.2	3285	3050	2815	2510	2345	2110
										19/1.3	3420	3180	2935	2615	2450	2200
										20/1.4	3605	3350	3090	2755	2575	2320
	22/1.5	3905	3625							3350	2985	2790	2510			
	23/1.6	4115	3820							3530	3145	2940	2645			
	26/1.8	4200	3900							3600	3210	3000	2700			
	29/2.0	4590	4265							3935	3510	3280	2955			
	32/2.2	4730	4395							4055	3615	3380	3045			
	33/2.3	4830	4485							4140	3690	3450	3105			
	29/2.0	4595	4265							3935	3510	3280	2955			
32/2.2	5210	4840	4465	3980	3720	3350										
35/2.4	5600	5200	4800	4280	4000	3600										
12.4-36	8	TT	126/A6	W11	W9, W10	315	1465	4366	678	29/2.0	2260	2100	1940	1730	1615	1455
										32/2.2	2330	2165	2000	1780	1665	1500
										33/2.3	2380	2210	2040	1820	1700	1530
	51/3.5	4520	3165							2112	2420	2260	2035			
	55/3.8	4715	3300							2155	2520	2360	2120			
	59/4.1	4860	3400							2220	2600	2430	2190			

Load capacity on recommended speed and pressure is stated with dark colour.

Tractor Rear · Characteristics of **TR-60**

Tire Size	PR	TT/TL	Load/Speed Index	Rims		Inflated Dimensions (No Load)		Inflated Dimensions (W/Load)		Inflation Pressure (psi/bar)	Load capacity per tire, kg					
				Recom (inch)	Permitted (inch)	Section Width (mm)	Outer Diameter (mm)	Dynamic Rolling Circumference (mm)	Static Loaded Radius (mm)		Speed, km/h					
											10	15	20	25	30	40
13.6-36	6	TT	125/A6	W12	W11	345	1515	4515	698	20/1.4	2105	1960	1805	1610	1505	1355
										22/1.5	2220	2060	1900	1695	1585	1430
										23/1.7	2310	2145	1980	1765	1650	1485
	8	TT	129/A6							28/1.9	2465	2290	2112	1885	1760	1585
										29/2.0	2510	2335	2155	1920	1795	1615
										32/2.2	2590	2405	2220	1980	1850	1665
13.6-38	8	TT	131/A6	W12	W11	345	1565	4664	723	25/1.7	2485	2305	2190	1900	1775	1600
										26/1.8	2595	2410	2225	1985	1855	1670
										29/2.0	2730	2535	2340	2085	1950	1755
	14	TT	142/A6							41/2.8	4875	3415	2925	2610	2440	2195
										44/3.0	5090	3560	3055	2720	2545	2289,6
										48/3,3	5300	3710	3180	2835,5	2650	2385
14.00-38	8	TT	131/A6	W12	W11	350	1570	4679	725	25/1.7	2485	2305	2190	1900	1775	1600
										26/1.8	2595	2410	2225	1985	1855	1670
										29/2.0	2730	2535	2340	2085	1950	1755
	10	TT	136/A6							29/2.0	2980	2770	2555	2280	2130	1920
										32/2.2	3070	2855	2635	2350	2195	1975
										33/2.3	3135	2910	2690	2395	2240	2015

Load capacity on recommended speed and pressure is stated with dark colour.

DESCRIPTION

- * For load capacity on various speed ratings, and inflation figures, please consult your sales representative.
- ** Load capacity on standard speed and weight

- Our company is entitled to make any change on any information in this catalogue, without further notice.
- This catalogue annuls all the previous catalogues
- All figures are for reference; our company is not responsible for printing errors.

Tractor Rear · Characteristics of **TR-60**

Tire Size	PR	TT/TL	Load/Speed Index	Rims		Inflated Dimensions (No Load)		Inflated Dimensions (W/Load)		Inflation Pressure (psi/bar)	Load capacity per tire, kg					
				Recom (inch)	Permitted (inch)	Section Width (mm)	Outer Diameter (mm)	Dynamic Rolling Circumference (mm)	Static Loaded Radius (mm)		Speed, km/h					
											10	15	20	25	30	40
15.5-38	8	TT	133/A6	W14L	-	394	1570	4679	725	22/1.5	2680	2490	2300	2050	1915	1725
										23/1.6	2830	2625	2425	2160	2020	1820
										26/1.8	2885	2680	2470	2205	2060	1855
	10	TT	138/A6							28/1.9	3145	2920	2695	2400	2245	2020
										29/2.0	3205	2980	2750	2450	2290	2060
										32/2.2	3305	3070	2830	2525	2360	2125
	12	TT	142/A6							29/2.0	3265	3030	2800	2495	2330	2100
										32/2.2	3485	2340	2990	2665	2490	2240
										34/2.3	3710	3445	3180	2835	2650	2385
										37/2.5	3570	2700	3060	2730	2550	2300
14	TT	145/A6	41/2.8	3815	2885	3270	2915	2725	2450							
			44/3.0	4060	3770	3480	3100	2900	2610							
16.9-38	8	TT	141/A6	W15L	W14L	429	1685	5021	771	20/1.4	3280	3050	2815	2510	2345	2110
										22/1.5	3420	3180	2935	2615	2445	2200
										25/1.7	3605	3350	3090	2755	2575	2320
	10	TT	144/A6							25/1.7	3570	3315	3060	2730	2550	2295
										26/1.8	3725	3460	3190	2845	2660	2395
										29/2.0	3920	3640	3360	3000	2800	2520
	12	TT	142/A6							25/1.7	3570	3315	3060	2730	2550	2295
										26/1.8	3725	3460	3190	2845	2660	2395
										29/2.0	3920	3640	3360	3000	2800	2520
18.4-38	8	TT	143/A6	W16L	W15L	467	1750	5215	797	17/1.2	3470	3225	2975	2650	2480	2235
										19/1.3	3625	3365	3110	2770	2590	2330
										20/1.4	3815	3545	3270	2915	2725	2455
	10	TT	147/A6							22/1.5	4090	3795	3505	3125	2920	2630
										23/1.6	4180	3880	3580	3195	2985	2690
										26/1.8	4305	4000	3690	3290	3075	2770
	10	TL	147/A6							22/1.5	4090	3795	3505	3125	2920	2630
										23/1.6	4180	3880	3580	3195	2985	2690
										26/1.8	4305	4000	3690	3290	3075	2770
14	TT	155/A8														

Load capacity on recommended speed and pressure is stated with dark colour.



TR-65

Tractor Rear

PERFORMANCE INFORMATION

Tractor rear tire for field operations.



FEATURES

Long service life / Durability

Resistant to cuts and wears thanks to its special compound.

Strong nylon carcass structure provides optimum durability.

High traction / Self-cleaning

High lugs provide excellent traction at all operating conditions.

Safe handling on steep or hilly grounds.

SIZE 16.9/14-30

Tractor Rear · Characteristics of **TR-65**

Tire Size	PR	TT/TL	Load/Speed Index	Rims		Inflated Dimensions (No Load)		Inflated Dimensions (W/Load)		Inflation Pressure (psi/bar)	Load capacity per tire, kg					
				Recom (inch)	Permitted (inch)	Section Width (mm)	Outer Diameter (mm)	Dynamic Rolling Circumference (mm)	Static Loaded Radius (mm)		Speed, km/h					
											10	15	20	25	30	40
16.9-14-30	10	TT	139/A6	W15L	W14L	429	1485	4425	671	29/2,0	3200	2970	2745	2445	2285	2060
										32/2,2	3330	3095	2855	2545	2380	2145
										35/2,4	3400	3160	2915	2600	2430	2190
	29/2,0	3680	3420							3155	2815	2630	2365			
	32/2,2	3800	3530							3260	2905	2715	2445			
	35/2,4	3920	3640							3360	2995	2800	2520			

Load capacity on recommended speed and pressure is stated with dark colour.

DESCRIPTION

- * For load capacity on various speed ratings, and inflation figures, please consult your sales representative.
- ** Load capacity on standard speed and weight

- Our company is entitled to make any change on any information in this catalogue, without further notice.
- This catalogue annuls all the previous catalogues
- All figures are for reference; our company is not responsible for printing errors.

TR-300

Tractor Rear

PERFORMANCE INFORMATION

R-1 tractor rear tire.



FEATURES

Long service life / Durability

Resistant to cuts and wears thanks to its special compound.

Strong nylon carcass structure provides optimum durability.

Open center pattern ensures high resistance to tread base fatigue.

High traction / Self-cleaning

Special lug design provides maximum traction while simultaneously offering excellent self-cleaning feature.

Ensures handling stability on steep or hilly grounds.

SIZES

9.5-24 • 11.2-24 • 12.4-24 • 13.6-24 • 14.9-24 • 12.4-28 • 13.6-28 • 14.9-28 • 14.9-30
16.9-30 • 18.4-30 • 16.9-34 • 18.4-34 • 12.4-36 • 13.6-36 • 16.9-38

Tractor Rear · Characteristics of **TR-300**

Tire Size	PR	TT/TL	Load/Speed Index	Rims		Inflated Dimensions (No Load)		Inflated Dimensions (W/Load)		Inflation Pressure (psi/bar)	Load capacity per tire, kg					
				Recom (inch)	Permitted (inch)	Section Width (mm)	Outer Diameter (mm)	Dynamic Rolling Circumference (mm)	Static Loaded Radius (mm)		Speed, km/h					
											10	15	20	25	30	40
9.5-24	8	TT	112/A6	W8	W7	241	1050	3180	490	33/2.3	1425	1325	1225	1090	1020	915
										36/2.5	1490	1385	1275	1140	1065	690
										41/2.8	1570	1455	1345	1200	1120	1010
11.2-24	8	TT	116/A6	W10	W9	284	1105	3310	505	29/2.0	1630	1510	1395	1245	1160	1045
										32/2.2	1680	1560	1440	1285	1200	1080
										35/2.4	1750	1625	1500	1340	1250	1125
12.4-24	8	TT	120/A6	W11	W9, W10	315	1160	3465	530	29/2.0	1860	1730	1595	1420	1330	1200
										32/2.2	1920	1780	1645	1470	1370	1235
										33/2.3	1960	1820	1680	1500	1400	1260
	33/2.3	2015	1870							1730	1540	1440	1355			
	10	TT	124/A6							36/2.5	2130	1975	1825	1625	1520	1395
										41/2.8	2240	2080	1920	1710	1600	1440
20/1.4				1975	1835	1695	1510	1410	1270							
13.6-24	8	TT	123/A6	DW12	DW11	345	1200	3625	541	22/1.5	2085	1935	1785	1590	1490	1340
										23/1.6	2170	2015	1860	1660	1550	1395
										22/1.5	2395	2225	2050	1830	1710	1540
14.9-24	8	TT	128/A6	W13	W11, W12	378	1265	3770	565	23/1.6	2445	2270	2095	1870	1745	1570
										26/1.8	2520	2340	2160	1925	1800	1620
										29/2.0	1995	1855	1710	1525	1425	1285
12.4-28	8	TT	122/A6	W11	W9, W10	315	1260	3770	582	32/2.2	2060	1910	1765	1575	1470	1325
										33/2.3	2100	1950	1800	1605	1500	1350
										25/1.7	2170	2015	1860	1660	1550	1395
13.6-28	8	TT	125/A6	W12	W11	345	1310	3905	602	28/1.9	2265	2100	1940	1730	1615	1455
										29/2.0	2310	2145	1980	1765	1650	1485
										29/2.0	1995	1855	1710	1525	1425	1285

Load capacity on recommended speed and pressure is stated with dark colour.

DESCRIPTION

- * For load capacity on various speed ratings, and inflation figures, please consult your sales representative.
- ** Load capacity on standard speed and weight

- Our company is entitled to make any change on any information in this catalogue, without further notice.
- This catalogue annuls all the previous catalogues
- All figures are for reference; our company is not responsible for printing errors.

Tractor Rear · Characteristics of **TR-300**

Tire Size	PR	TT/TL	Load/Speed Index	Rims		Inflated Dimensions (No Load)		Inflated Dimensions (W/Load)		Inflation Pressure (psi/bar)	Load capacity per tire, kg					
				Recom (inch)	Permitted (inch)	Section Width (mm)	Outer Diameter (mm)	Dynamic Rolling Circumference (mm)	Static Loaded Radius (mm)		Speed, km/h					
											10	15	20	25	30	40
14.9-28	8	TT	130/A6	W13	W11, W12	378	1365	4070	622	22/1.5	2530	2345	2165	1930	1805	1625
										23/1.6	2580	2400	2215	1975	1845	1660
										26/1.8	2660	2470	2280	2035	1900	1710
14.9-30	8	TT	131/A6	W13	W11, W12	378	1415	4230	660	22/1.5	2594	2410	2223	1982	1853	1667
										23/1.6	2648	2460	2270	2024	1892	1702
										26/1.8	2730	2535	2340	2087	1950	1755
16.9-30	10	TT	139/A6	W15L	W14L	429	1485	4430	668	25/1.7	3200	2970	2740	2445	2285	2055
										26/1.8	3265	3035	2800	2495	2335	2100
										29/2.0	3400	3160	2915	2600	2430	2190
18.4-30	8	TT	139/A6	W16L	W15L	467	1550	4610	698	17/1.2	3095	2875	2655	2365	2210	1990
										19/1.3	3230	3000	2770	2470	2310	2080
										20/1.4	3400	3160	2915	2600	2430	2185
										22/1.5	3860	3580	3305	2950	2755	2480
										23/1.6	3940	3660	3375	3010	2815	2530
										26/1.8	4060	3770	3480	3100	2900	2610
										28/1.9	4230	3930	3625	3230	3025	2720
										30/2.1	4415	4095	3780	3371	3150	2835
										33/2.3	4550	4225	3900	3475	3250	2925
										33/2.2	4540	4220	3890	3470	3245	2920
35/2.4	4685	4350	4015	3580	3345	3010										
38/2.6	4830	4485	4140	3690	3450	3105										
16.9-34	8	TT	139/A6	W15L	W14L	429	1585	4715	725	22/1.5	3230	3000	2770	2470	2310	2080
										23/1.6	3300	3070	2830	2525	2360	2120
										25/1.7	3400	3160	2915	2600	2430	2190
18.4-34	8	TT	141/A6	W16L	W15L	467	1650	4915	750	17/1.2	3280	3050	2815	2510	2345	2110
										19/1.3	3425	3180	2935	2615	2445	2200
										20/1.4	3605	3350	3090	2755	2575	2320

Load capacity on recommended speed and pressure is stated with dark colour.

DESCRIPTION

* For load capacity on various speed ratings, and inflation figures, please consult your sales representative.

** Load capacity on standard speed and weight

- Our company is entitled to make any change on any information in this catalogue, without further notice.
- This catalogue annuls all the previous catalogues
- All figures are for reference; our company is not responsible for printing errors.

Tractor Rear · Characteristics of **TR-300**

Tire Size	PR	TT/TL	Load/Speed Index	Rims		Inflated Dimensions (No Load)		Inflated Dimensions (W/Load)		Inflation Pressure (psi/bar)	Load capacity per tire, kg					
				Recom (inch)	Permitted (inch)	Section Width (mm)	Outer Diameter (mm)	Dynamic Rolling Circumference (mm)	Static Loaded Radius (mm)		Speed, km/h					
											10	15	20	25	30	40
12.4-36	8	TT	126/A6	W11	W9, W10	315	1465	4365	682	29/2.0	2260	2100	1940	1730	1615	1455
										32/2.2	2335	2165	2000	1785	1665	1500
										33/2.3	2380	2210	2040	1820	1700	1530
13.6-36	8	TT	129/A6	W12	W11	345	1515	4520	692	28/1.9	2460	2290	2110	1880	1760	1580
										29/2.0	2515	2330	2155	1920	1795	1615
										32/2.2	2590	2405	2220	1980	1850	1665
16.9-38	8	TT	141/A6	W15L	W14L	429	1685	4950	767	22/1.5	3425	3180	2940	2615	2445	2200
										23/1.6	3500	3250	3000	2675	2500	2250
										25/1.7	3605	3350	3090	2755	2575	2320

Load capacity on recommended speed and pressure is stated with dark colour.

DESCRIPTION

- * For load capacity on various speed ratings, and inflation figures, please consult your sales representative.
 - ** Load capacity on standard speed and weight
-
- Our company is entitled to make any change on any information in this catalogue, without further notice.
 - This catalogue annuls all the previous catalogues
 - All figures are for reference; our company is not responsible for printing errors.



TR-330

Tractor Rear

PERFORMANCE INFORMATION

R-1 tractor rear tire.



FEATURES

Long service life / Durability

Exceptional carcass structure provides optimum durability.

Tread profile with extra wide tread base ensures perfect resistance to tread base fatigue.

High traction / Self-cleaning

Provides superior performance on tough terrains with its specially designed tread pattern.

The unique lug design prevents any kind of crop damage and provides easy cleaning feature during field operations.

Wide and reinforced body provides perfect grip, high traction and reduced slippage.

SIZE 30.5L-32

Tractor Rear · Characteristics of **TR-330**

Tire Size	PR	TT/TL	Load/Speed Index	Rims		Inflated Dimensions (No Load)		Inflated Dimensions (W/Load)		Inflation Pressure (psi/bar)	Load capacity per tire, kg				
				Recom (inch)	Permitted (inch)	Section Width (mm)	Outer Diameter (mm)	Dynamic Rolling Circumference (mm)	Static Loaded Radius (mm)		Speed, km/h				
											10	15	20	25	30
30.5L-32	12	TL	158/A8	DW27B	DHB27 DH27B DH27H	770	1819	5420	820	20/1.4	6375	5230	4550	4250	

Load capacity on recommended speed and pressure is stated with dark colour.

DESCRIPTION

- * For load capacity on various speed ratings, and inflation figures, please consult your sales representative.
 - ** Load capacity on standard speed and weight
-
- Our company is entitled to make any change on any information in this catalogue, without further notice.
 - This catalogue annuls all the previous catalogues
 - All figures are for reference; our company is not responsible for printing errors.



Tractor Radial /
Row Crop

RADIAL

TR-110

TR-110 PLUS

TR-120 Row Crop

TR-130

TR-130 PLUS

TR-130 IF SERIES

TR-130

TR-130 PLUS

TR-130 IF



TR-110

TR-120
Row Crop

TR-130
PLUS

TR-110
PLUS

TR-130

TR-130
IF SERIES

Row Crop



TR-110 /65 Tractor Radial

PERFORMANCE INFORMATION

General purpose **R-1W** tractor radial tire.



FEATURES

Long service life / Durability

Special tread compound provides high level of resistance against wear and cuts.

Tread profile enhances durability to tread base fatigue.

High traction

Low rolling resistance leads to maximum fuel efficiency.

Unique tread design provides exceptional traction and ensures maximum performance.

Low soil compaction / Reduced slip

Wider footprint offers lower soil compaction.

Special structure improves flotation on soft terrains and ensures a comfortable ride at all operating conditions.

SIZES

420/65 R24 · 440/65 R24 · 480/65 R24 · 540/65 R24 · 440/65 R28 · 480/65 R28
540/65 R28 · 540/65 R30 · 540/65 R34 · 600/65 R34 · 540/65 R38 · 600/65 R38

Tractor Radial · Characteristics of **TR-110/65**

Tire Size	TT/TL	Load/Speed Index	Rims		Inflated Dimensions (No Load)		Inflated Dimensions (W/Load)		Inflation Pressure (psi/bar)	Load capacity per tire, kg				
			Recom (inch)	Permitted (inch)	Section Width (mm)	Outer Diameter (mm)	Dynamic Rolling Circumference (mm)	Static Loaded Radius (mm)		Speed, km/h				
										10	30	40	50	65
420/65 R24	TL	138 D/141 AB	W13	W11, W12, DW12, DW13	418	1156	3468	524	9/0,6	1485	1275	1210	1165	1110
									12/0,8	1705	1465	1390	1340	1275
									15/1,0	1960	1680	1600	1540	1460
									17/1,2	2210	1900	1800	1735	1650
									20/1,4	2465	2120	2010	1935	1840
									23/1,6	2715	2335	2215	2130	2030
									26/1,8	2840	2440	2315	2230	2125
									29/2,0	2970	2550	2420	2330	2220
									32/2,2	3065	2630	2500	2405	2290
								35/2,4	3160	2715	2575	2480	2360	
440/65 R24	TL	135 D/138 A8	W14L	W13, W15L	441	1182	3546	534	9/0,6	1370	1180	1110	1075	1025
									12/0,8	1605	1380	1300	1260	1200
									15/1,0	1840	1580	1490	1445	1375
									17/1,2	2045	1755	1650	1600	1525
									20/1,4	2335	2005	1890	1830	1745
									23/1,6	2425	2080	1960	1900	1810
									26/1,8	2570	2205	2075	2015	1920
									29/2,0	2715	2330	2195	2130	2030
									32/2,2	2820	2420	2280	2210	2105
								35/2,4	2920	2505	2360	2290	2180	
480/65 R24	TL	140 D/143 A8	W15L	W14L	479	1234	3702	555	9/0,6	1575	1350	1280	1235	1175
									12/0,8	1845	1580	1500	1445	1375
									15/1,0	2110	1810	1720	1655	1575
									17/1,2	2345	2015	1910	1840	1750
									20/1,4	2580	2215	2100	2020	1925
									23/1,6	2780	2385	2260	2180	2075
									26/1,8	2950	2530	2400	2310	2200
									29/2,0	3115	2675	2535	2440	2325
									32/2,2	3235	2775	2630	2535	2415
								35/2,4	3350	2875	2725	2625	2500	

Load capacity on recommended speed and pressure is stated with dark colour.

DESCRIPTION

- * For load capacity on various speed ratings, and inflation figures, please consult your sales representative.
- ** Load capacity on standard speed and weight

- Our company is entitled to make any change on any information in this catalogue, without further notice.
- This catalogue annuls all the previous catalogues
- All figures are for reference; our company is not responsible for printing errors.

Tractor Radial · Characteristics of **TR-110/65**

Tire Size	TT/TL	Load/Speed Index	Rims		Inflated Dimensions (No Load)		Inflated Dimensions (W/Load)		Inflation Pressure (psi/bar)	Load capacity per tire, kg				
			Recom (inch)	Permitted (inch)	Section Width (mm)	Outer Diameter (mm)	Dynamic Rolling Circumference (mm)	Static Loaded Radius (mm)		Speed, km/h				
										10	30	40	50	65
540/65 R24	TL	146 D/ 149 A8	W16L	W18L	550	1312	3936	586	9/0,6	1890	1620	1530	1480	1410
									12/0,8	2210	1900	1790	1735	1650
									15/1,0	2535	2175	2050	1985	1890
									17/1,2	2815	2415	2275	2205	2100
									20/1,4	3100	2660	2500	2425	2310
									23/1,6	3340	2865	2700	2615	2490
									26/1,8	3540	3035	2860	2770	2640
									29/2,0	3740	3210	3025	2930	2790
									32/2,2	3880	3330	3135	3040	2895
								35/2,4	4020	3450	3250	3150	3000	
440/65 R28	TL	138 D/ 141 A8	W14L	W13- W15L	441	1283	3849	585	9/0,6	1485	1275	1210	1170	1110
									12/0,8	1740	1495	1415	1365	1300
									15/1,0	1990	1710	1620	1560	1490
									17/1,2	2210	1900	1805	1735	1650
									20/1,4	2530	2170	2060	1985	1890
									23/1,6	2625	2250	2140	2060	1960
									26/1,8	2780	2390	2265	2180	2080
									29/2,0	2940	2525	2395	2305	2195
									32/2,2	3050	2620	2485	2395	2280
								35/2,4	3160	2715	2575	2480	2360	
480/65 R28	TL	142 D/ 145 A8	W15L	W14L	479	1335	4005	605	9/0,6	1670	1435	1365	1305	1245
									12/0,8	1955	1680	1595	1530	1460
									15/1,0	2240	1920	1830	1750	1670
									17/1,2	2485	2135	2030	1945	1855
									20/1,4	2735	2350	2235	2140	2040
									23/1,6	2950	2530	2410	2310	2200
									26/1,8	3125	2685	2550	2445	2330
									29/2,0	3300	2840	2700	2585	2465
									32/2,2	3425	2945	2800	2685	2555
								35/2,4	3550	3050	2900	2780	2650	
540/65 R28	TL	149 D/ 152 A8	W16L	W18L	535	1430,7	4248	637	9/0,6	2050	1755	1670	1600	1530
									12/0,8	2400	2060	1960	1880	1790
									15/1,0	2750	2360	2245	2150	2050
									17/1,2	3050	2615	2490	2400	2275
									20/1,4	3350	2875	2740	2625	2500
									23/1,6	3620	3105	2960	2835	2700
									26/1,8	3830	3290	3130	3000	2860
									29/2,0	4045	3470	3305	3170	3020
									32/2,2	4180	3590	3415	3275	3120
								35/2,4	4355	3740	3550	3415	3250	

Load capacity on recommended speed and pressure is stated with dark colour.



Tractor Radial · Characteristics of **TR-110/65**

Tire Size	TT/TL	Load/Speed Index	Rims		Inflated Dimensions (No Load)		Inflated Dimensions (W/Load)		Inflation Pressure (psi/bar)	Load capacity per tire, kg				
			Recom (inch)	Permitted (inch)	Section Width (mm)	Outer Diameter (mm)	Dynamic Rolling Circumference (mm)	Static Loaded Radius (mm)		Speed, km/h				
										10	30	40	50	65
540/65 R30	TL	150 D/ 153 A8	W16L	W18L	543.5	1477.2	4390	664	9/0,6	2110	1810	1720	1650	1575
									12/0,8	2465	2115	2015	1930	1840
									15/1,0	2830	2425	2310	2215	2110
									17/1,2	3140	2700	2570	2460	2345
									20/1,4	3455	2965	2825	2710	2580
									23/1,6	3725	3195	3045	2920	2780
									26/1,8	3955	3393	3230	3098	2950
									29/2,0	4175	3580	3410	3270	3115
									32/2,2	4310	3695	3520	3375	3215
35/2,4	4490	3855	3650	3520	3350									
540/65 R34	TL	152 D/ 155 A8	W16L	W18L	550	1566	4698	713	9/0,6	2240	1920	1820	1750	1670
									12/0,8	2620	2245	2130	2050	1955
									15/1,0	3000	2570	2440	2350	2240
									17/1,2	3330	2855	2710	2610	2485
									20/1,4	3665	3140	2985	2870	2735
									23/1,6	3950	3385	3215	3095	2945
									26/1,8	4190	3590	3410	3280	3125
									29/2,0	4425	3795	3605	3470	3300
									32/2,2	4590	3935	3740	3600	3425
35/2,4	4760	4080	3875	3730	3550									
600/65 R34	TL	157 D/ 160 A8	DW20B	W18L	591	1644	4932	745	9/0,6	2600	2230	2115	2035	1940
									12/0,8	3040	2610	2475	2380	2270
									15/1,0	3485	2985	2835	2730	2600
									17/1,2	3870	3320	3150	3030	2890
									20/1,4	4260	3650	3465	3335	3175
									23/1,6	4590	3935	3735	3595	3425
									26/1,8	4865	4170	3960	3810	3630
									29/2,0	5140	4410	4185	4030	3835
									32/2,2	5335	4575	4343	4180	3980
35/2,4	5530	4740	4500	4330	4125									

Load capacity on recommended speed and pressure is stated with dark colour.

DESCRIPTION

- * For load capacity on various speed ratings, and inflation figures, please consult your sales representative.
- ** Load capacity on standard speed and weight
- Our company is entitled to make any change on any information in this catalogue, without further notice.
- This catalogue annuls all the previous catalogues
- All figures are for reference; our company is not responsible for printing errors.

Tractor Radial · Characteristics of **TR-110/65**

Tire Size	TT/TL	Load/Speed Index	Rims		Inflated Dimensions (No Load)		Inflated Dimensions (W/Load)		Inflation Pressure (psi/bar)	Load capacity per tire, kg				
			Recom (inch)	Permitted (inch)	Section Width (mm)	Outer Diameter (mm)	Dynamic Rolling Circumference (mm)	Static Loaded Radius (mm)		Speed, km/h				
										10	30	40	50	65
540/65 R38	TL	153 D/ 156 A8	W16L	W18L	550	1667	5001	764	9/0,6	2300	1975	1880	1800	1715
									12/0,8	2690	2310	2200	2110	2010
									15/1,0	3080	2645	2520	2415	2300
									17/1,2	3420	2940	2800	2680	2555
									20/1,4	3765	3235	3080	2950	2810
									23/1,6	4060	3485	3320	3180	3030
									26/1,8	4300	3695	3520	3370	3210
									29/2,0	4550	3905	3720	3560	3395
									32/2,2	4720	4055	3860	3695	3520
									35/2,4	4890	4200	4000	3830	3650
600/65 R38	TL	159 D/ 162 A8	DW20B	W18L	591	1747	5229	786	9/0,6	2754	2363	2250	2160	2055
									12/0,8	3225	2765	2635	2525	2405
									15/1,0	3695	3168	3020	2895	2755
									17/1,2	4100	3520	3350	3215	3060
									20/1,4	4515	3875	3690	3535	3370
									23/1,6	4865	4175	3975	3810	3630
									26/1,8	5160	4430	4215	4045	3850
									29/2,0	5455	4680	4455	4275	4070
									32/2,2	5630	4830	4600	4410	4200
									35/2,4	5865	5035	4750	4595	4375

Load capacity on recommended speed and pressure is stated with dark colour.

DESCRIPTION

- * For load capacity on various speed ratings, and inflation figures, please consult your sales representative.
- ** Load capacity on standard speed and weight

- Our company is entitled to make any change on any information in this catalogue, without further notice.
- This catalogue annuls all the previous catalogues
- All figures are for reference; our company is not responsible for printing errors.







TR-110 /70

Tractor Radial

PERFORMANCE INFORMATION

General purpose **R-1W** tractor radial tire.



FEATURES

Long service life / Durability

Special tread compound provides high level of resistance against wear and cuts.

Tread profile enhances durability to tread base fatigue.

High traction

Low rolling resistance leads to maximum fuel efficiency.

Unique tread design provides exceptional traction and ensures maximum performance.

Low soil compaction / Reduced slip

Wider footprint offers lower soil compaction.

Special structure improves flotation on soft terrains and ensures a comfortable ride at all operating conditions.

SIZES

200/70 R16 · 240/70 R16 · 260/70 R16 · 280/70 R16 · 280/70 R18 · 260/70 R20 · 280/70 R20
300/70 R20 · 320/70 R20 · 360/70 R20 · 380/70 R20 · 320/70 R24 · 360/70 R24 · 380/70 R24
420/70 R24 · 480/70 R24 · 480/70 R26 · 320/70 R28 · 360/70 R28 · 380/70 R28 · 420/70 R28
480/70 R28 · 420/70 R30 · 480/70 R30 · 520/70 R30 · 480/70 R34 · 520/70 R34 · 480/70 R38
520/70 R38 · 580/70 R38 · 580/70 R42

Tractor Radial · Characteristics of **TR-110/70**

Tire Size	TT/TL	Load/Speed Index	Rims		Inflated Dimensions (No Load)		Inflated Dimensions (W/ Load)		Inflation Pressure (psi/bar)	Load capacity per tire, kg			
			Recom (inch)	Permitted (inch)	Section Width (mm)	Outer Diameter (mm)	Dynamic Rolling Circumference (mm)	Static Loaded Radius (mm)		Speed, km/h			
										10	30	40	50
200/70 R16	TL	94 A8 / 94 B	W6	W6	197	691	2050	312	9 / 0.6	425	340	315	315
									12 / 0.8	485	390	365	365
									15 / 1.0	560	445	420	420
									17 / 1.2	630	505	470	470
									20 / 1.4	705	560	525	525
									23 / 1.6	775	620	580	580
									26 / 1.8	810	650	605	605
									29 / 2.0	845	675	630	630
									32 / 2.2	875	700	650	650
								35 / 2.4	900	720	670	670	
240/70 R16	TL	104 A8 / 101 B	W8	W8L, W9	244	741.6	2219	334	9 / 0.6	570	455	425	385
									12 / 0.8	655	525	490	445
									15 / 1.0	750	600	560	510
									17 / 1.2	845	675	630	575
									20 / 1.4	945	755	705	640
									23 / 1.6	1040	830	775	705
									26 / 1.8	1090	870	810	740
									29 / 2.0	1135	910	850	770
									32 / 2.2	1170	935	875	795
								35 / 2.4	1210	965	900	825	
260/70 R16	TL	109 A8 / 106 B	W8	W8L, W9	258	770	2302	345	9 / 0.6	650	520	485	445
									12 / 0.8	750	600	560	510
									15 / 1.0	860	685	640	585
									17 / 1.2	970	775	725	660
									20 / 1.4	1080	860	805	735
									23 / 1.6	1190	950	890	810
									26 / 1.8	1245	995	930	845
									29 / 2.0	1300	1040	970	885
									32 / 2.2	1340	1070	1000	910
								35 / 2.4	1385	1105	1030	950	

Load capacity on recommended speed and pressure is stated with dark colour.

DESCRIPTION

* For load capacity on various speed ratings, and inflation figures, please consult your sales representative.

** Load capacity on standard speed and weight

- Our company is entitled to make any change on any information in this catalogue, without further notice.
- This catalogue annuls all the previous catalogues
- All figures are for reference; our company is not responsible for printing errors.



Tractor Radial · Characteristics of **TR-110/70**

Tire Size	TT/TL	Load/Speed Index	Rims		Inflated Dimensions (No Load)		Inflated Dimensions (W/ Load)		Inflation Pressure (psi/bar)	Load capacity per tire, kg			
			Recom (inch)	Permitted (inch)	Section Width (mm)	Outer Diameter (mm)	Dynamic Rolling Circumference (mm)	Static Loaded Radius (mm)		Speed, km/h			
										10	30	40	50
280/70 R16	TL	112 A8 / 112 B	W9	W8, W8L W10	282	805	2390	358	9/0.6	710	565	530	530
									12/0.8	815	650	605	605
									15/1.0	935	745	695	695
									17/1.2	1055	840	785	785
									20/1.4	1175	935	875	875
									23/1.6	1295	1035	965	965
									26/1.8	1355	1080	1010	1010
									29/2.0	1415	1130	1055	1055
									32/2.2	1460	1165	1090	1090
35/2.4	1505	1200	1120	1120									
280/70 R18	TL	114 A8 / 114 B	W9	W8, W10	282	846	2540	384	9/0.6	745	595	555	555
									12/0.8	855	685	640	640
									15/1.0	985	785	735	735
									17/1.2	1110	885	830	830
									20/1.4	1235	985	925	925
									23/1.6	1360	1090	1015	1015
									26/1.8	1425	1140	1065	1065
									29/2.0	1490	1190	1110	1110
									32/2.2	1535	1225	1145	1145
35/2.4	1585	1265	1180	1180									
260/70 R20	TL	113 A8 / 113 B	W8	W9, 9	258	880	2635	397	9/0.6	725	580	545	545
									12/0.8	835	665	625	625
									15/1.0	960	765	715	715
									17/1.2	1080	865	805	805
									20/1.4	1205	960	900	900
									23/1.6	1330	1060	990	990
									26/1.8	1390	1110	1035	1035
									29/2.0	1450	1160	1085	1085
									32/2.2	1495	1195	1120	1120
35/2.4	1545	1235	1150	1150									
280/70 R20	TL	116 A8 / 116 B	W9	W10	282	912	2736	416	9/0.6	790	630	590	590
									12/0.8	905	725	675	675
									15/1.0	1040	830	775	775
									17/1.2	1175	940	875	875
									20/1.4	1310	1045	975	975
									23/1.6	1445	1155	1075	1075
									26/1.8	1510	1205	1125	1125
									29/2.0	1575	1260	1175	1175
									32/2.2	1625	1300	1215	1215
35/2.4	1675	1340	1250	1250									

Load capacity on recommended speed and pressure is stated with dark colour.

Tractor Radial · Characteristics of **TR-110/70**

Tire Size	TT/TL	Load/Speed Index	Rims		Inflated Dimensions (No Load)		Inflated Dimensions (W/ Load)		Inflation Pressure (psi/bar)	Load capacity per tire, kg			
			Recom (inch)	Permitted (inch)	Section Width (mm)	Outer Diameter (mm)	Dynamic Rolling Circumference (mm)	Static Loaded Radius (mm)		Speed, km/h			
										10	30	40	50
300/70 R20	TL	120 A8 / 120 B	W9	W10	290	954	2811	435	9/0,6	880	705	660	660
									12/0,8	1010	810	756	756
									15/1,0	1160	930	870	870
									17/1,2	1310	1050	980	980
									20/1,4	1460	1170	1090	1090
									23/1,6	1610	1290	1205	1205
									29/2,0	1760	1410	1315	1315
									35/2,4	1875	1500	1400	1400
320/70 R20	TL	123 A8 / 123 B	W10	W9, W11	319	983	2919	442	9/0,6	980	780	730	730
									12/0,8	1125	895	840	840
									15/1,0	1290	1030	960	960
									17/1,2	1455	1160	1085	1085
									20/1,4	1620	1295	1210	1210
									23/1,6	1790	1430	1330	1330
									29/2,0	1955	1560	1460	1460
									35/2,4	2080	1660	1550	1550
360/70 R20	TL	129 A8 / 129 B	W11	W10, W12	357	1042	3116	463	9/0,6	1165	930	870	870
									12/0,8	1340	1070	1000	1000
									15/1,0	1540	1230	1150	1150
									17/1,2	1735	1385	1295	1295
									20/1,4	1935	1545	1445	1445
									23/1,6	2130	1700	1590	1590
									29/2,0	2330	1860	1740	1740
									35/2,4	2480	1980	1850	1850
380/70 R20	TL	132 A8 / 132 B	W12	W11, W13	380	1082	3246	484	9/0,6	1260	1010	940	940
									12/0,8	1450	1160	1080	1080
									15/1,0	1665	1330	1240	1240
									17/1,2	1880	1500	1400	1400
									20/1,4	2095	1670	1560	1560
									23/1,6	2305	1845	1720	1720
									26/1,8	2415	1930	1800	1800
									29/2,0	2520	2015	1880	1880
									32/2,2	2600	2080	1940	1940
									35/2,4	2680	2140	2000	2000

Load capacity on recommended speed and pressure is stated with dark colour.

DESCRIPTION

- * For load capacity on various speed ratings, and inflation figures, please consult your sales representative.
- ** Load capacity on standard speed and weight

- Our company is entitled to make any change on any information in this catalogue, without further notice.
- This catalogue annuls all the previous catalogues
- All figures are for reference; our company is not responsible for printing errors.



Tractor Radial · Characteristics of **TR-110/70**

Tire Size	TT/TL	Load/Speed Index	Rims		Inflated Dimensions (No Load)		Inflated Dimensions (W/ Load)		Inflation Pressure (psi/bar)	Load capacity per tire, kg				
			Recom (inch)	Permitted (inch)	Section Width (mm)	Outer Diameter (mm)	Dynamic Rolling Circumference (mm)	Static Loaded Radius (mm)		Speed, km/h				
										10	30	40	50	65
320/70 R24	TL	116 D	W10	W9, W11	319	1084	3271	494	9/0,6	925	790	750	720	690
									12/0,8	1075	920	875	840	800
									15/1,0	1225	1050	1000	960	915
									17/1,2	1375	1180	1120	1080	1025
									20/1,4	1525	1310	1245	1200	1140
23/1,6	1675	1440	1370	1315	1250									
360/70 R24	TL	122 D	W11	W10, W12	357	1152	3433	517	9/0,6	1110	950	900	860	825
									12/0,8	1290	1100	1050	1000	960
									15/1,0	1470	1260	1200	1150	1095
									17/1,2	1650	1410	1345	1290	1230
									20/1,4	1830	1570	1490	1430	1365
23/1,6	2010	1725	1640	1575	1500									
380/70 R24	TL	125 D	W12	W11, W13	380	1199	3562	538	9/0,6	1220	1045	995	950	910
									12/0,8	1420	1215	1160	1110	1060
									15/1,0	1615	1390	1320	1260	1205
									17/1,2	1815	1560	1485	1420	1355
									20/1,4	2015	1730	1650	1575	1505
23/1,6	2215	1900	1810	1730	1650									
420/70 R24	TL	130 D/133 A8	W13	W12, W14L	418	1248	3732	554	9/0,6	1405	1200	1145	1100	1045
									12/0,8	1630	1400	1330	1275	1220
									15/1,0	1860	1595	1515	1455	1390
									17/1,2	2090	1790	1705	1635	1560
									20/1,4	2320	1990	1890	1815	1730
23/1,6	2550	2185	2080	1995	1900									
480/70 R24	TL	138 D	W15L	W14L, W16L	479	1316	3885	576	9/0,6	1740	1495	1420	1365	1300
									12/0,8	2025	1740	1655	1590	1515
									15/1,0	2310	1980	1890	1810	1725
									17/1,2	2595	2225	2120	2030	1940
									20/1,4	2880	2470	2350	2255	2150
23/1,6	3165	2715	2585	2480	2360									

Load capacity on recommended speed and pressure is stated with dark colour.

DESCRIPTION

* For load capacity on various speed ratings, and inflation figures, please consult your sales representative.

** Load capacity on standard speed and weight

- Our company is entitled to make any change on any information in this catalogue, without further notice.
- This catalogue annuls all the previous catalogues
- All figures are for reference; our company is not responsible for printing errors.

Tractor Radial · Characteristics of **TR-110/70**

Tire Size	TT/TL	Load/Speed Index	Rims		Inflated Dimensions (No Load)		Inflated Dimensions (W/ Load)		Inflation Pressure (psi/bar)	Load capacity per tire, kg				
			Recom (inch)	Permitted (inch)	Section Width (mm)	Outer Diameter (mm)	Dynamic Rolling Circumference (mm)	Static Loaded Radius (mm)		Speed, km/h				
										10	30	40	50	65
480/70 R26	TL	139 A8 / 136 B	W15L	W14L, W16L	479	1369.6	4080	619	9/0.6	1795	1435	1340	1220	-
									12/0.8	2085	1665	1560	1420	-
									15/1.0	2380	1900	1775	1615	-
									17/1.2	2675	2135	1995	1815	-
									20/1.4	2965	2370	2215	2015	-
									23/1.6	3260	2605	2430	2240	-
320/70 R28	TL	119 A8 / 116 B	W10	W9, W11	119	1189	3555	547	9/0,6	1005	805	750	750	-
									12/0,8	1170	935	875	875	-
									15/1,0	1335	1065	995	995	-
									17/1,2	1495	1195	1120	1120	-
									20/1,4	1660	1325	1240	1240	-
									23/1,6	1825	1460	1360	1360	-
360/70 R28	TL	125 D	W11	W10, W12	357	1260	3780	570	9/0,6	1220	1045	995	950	910
									12/0,8	1420	1215	1160	1110	1060
									15/1,0	1615	1390	1320	1260	1205
									17/1,2	1815	1560	1485	1420	1355
									20/1,4	2015	1730	1650	1575	1505
									23/1,6	2215	1900	1810	1730	1650
380/70 R28	TL	127 D	W12	W11, W13	380	1297.4	3888	586	9/0,6	1290	1100	1050	1010	965
									12/0,8	1505	1285	1225	1180	1120
									15/1,0	1715	1470	1400	1340	1280
									17/1,2	1925	1650	1570	1510	1435
									20/1,4	2135	1830	1740	1675	1595
									23/1,6	2345	2010	1915	1840	1750
420/70 R28	TL	133 D	W13	W12, W14L	418	1349	4033	610	9/0,6	1520	1300	1240	1190	1135
									12/0,8	1770	1515	1445	1380	1320
									15/1,0	2020	1730	1645	1575	1505
									17/1,2	2265	1945	1850	1770	1690
									20/1,4	2515	2155	2050	1965	1875
									23/1,6	2765	2370	2255	2160	2060

Load capacity on recommended speed and pressure is stated with dark colour.

DESCRIPTION

* For load capacity on various speed ratings, and inflation figures, please consult your sales representative.

** Load capacity on standard speed and weight

- Our company is entitled to make any change on any information in this catalogue, without further notice.
- This catalogue annuls all the previous catalogues
- All figures are for reference; our company is not responsible for printing errors.



Tractor Radial · Characteristics of **TR-110/70**

Tire Size	TT/TL	Load/Speed Index	Rims		Inflated Dimensions (No Load)		Inflated Dimensions (W/ Load)		Inflation Pressure (psi/bar)	Load capacity per tire, kg				
			Recom (inch)	Permitted (inch)	Section Width (mm)	Outer Diameter (mm)	Dynamic Rolling Circumference (mm)	Static Loaded Radius (mm)		Speed, km/h				
										10	30	40	50	65
480/70 R28	TL	140 D	W15L	W14L, W16L	479	1421.2	4200	637	9/0,6	1845	1580	1510	1440	1375
									12/0,8	2145	1840	1750	1680	1600
									15/1,0	2450	2100	2000	1915	1825
									17/1,2	2750	2360	2245	2150	2050
									20/1,4	3050	2615	2495	2390	2275
23/1,6	3350	2875	2740	2625	2500									
420/70 R30	TL	134 D	W13	W12, W14L	418	1398	4166	630	9/0,6	1565	1340	1275	1220	1170
									12/0,8	1820	1560	1485	1424	1360
									15/1,0	2075	1780	1695	1625	1550
									17/1,2	2330	2000	1900	1825	1740
									20/1,4	2590	2220	2110	2045	1930
23/1,6	2845	2440	2320	2225	2120									
480/70 R30	TL	141 D	W15L	W14L, W16L	479	1478	4389	660	9/0,6	1900	1630	1550	1485	1420
									12/0,8	2210	1895	1800	1730	1650
									15/1,0	2520	2160	2060	1970	1880
									17/1,2	2830	2430	2310	2215	2115
									20/1,4	3140	2690	2565	2460	2345
23/1,6	3455	2960	2820	2700	2575									
520/70 R30	TL	145 A8 / 142 B	W16L	W15L, W18L	516	1557.4	4560	683	9/0,6	2140	1710	1595	1455	-
									12/0,8	2490	1990	1860	1690	-
									15/1,0	2840	2270	2120	1930	-
									17/1,2	3190	2545	2380	2165	-
									20/1,4	3540	2825	2640	2405	-
23/1,6	3890	3105	2900	2650	-									
480/70 R34	TL	149 D	W15L	W14L, W16L	479	1580	4708	712	9/0,6	2045	1760	1670	1600	1530
									12/0,8	2350	2020	1920	1840	1755
									15/1,0	2700	2320	2210	2115	2015
									17/1,2	3050	2620	2490	2390	2275
									20/1,4	3400	2915	2775	2660	2535
									23/1,6	3745	3215	3060	2930	2795
									26/1,8	3920	3365	3200	3070	2925
									29/2,0	4095	3515	3345	3205	3055
									32/2,2	4225	3630	3450	3310	3150
35/2,4	4355	3740	3560	3410	3250									

Load capacity on recommended speed and pressure is stated with dark colour.

Tractor Radial · Characteristics of **TR-110/70**

Tire Size	TT/TL	Load/Speed Index	Rims		Inflated Dimensions (No Load)		Inflated Dimensions (W/ Load)		Inflation Pressure (psi/bar)	Load capacity per tire, kg				
			Recom (inch)	Permitted (inch)	Section Width (mm)	Outer Diameter (mm)	Dynamic Rolling Circumference (mm)	Static Loaded Radius (mm)		Speed, km/h				
										10	30	40	50	65
520/70 R34	TL	148 D	W16L	W15L, W18L	516	1640	4920	737	9/0,6	2325	1990	1900	1820	1735
									12/0,8	2705	2315	2210	2120	2020
									15/1,0	3085	2640	2515	2415	2300
									17/1,2	3465	2970	2830	2715	2585
									20/1,4	3845	3295	3140	3010	2870
									23/1,6	4225	3620	3450	3310	3150
480/70 R38	TL	145 D	W15L	W14L, W16L	479	1681	4990	762	9/0,6	2140	1835	1745	1675	1595
									12/0,8	2490	2135	2030	1950	1860
									15/1,0	2840	2435	2315	2220	2120
									17/1,2	3190	2735	2600	2500	2380
									20/1,4	3540	3035	2890	2770	2640
									23/1,6	3890	3335	3175	3045	2900
520/70 R38	TL	150 D	W16L	W15L, W18L	516	1749	5212	789	9/0,6	2470	2120	2020	1930	1845
									12/0,8	2875	2464	2350	2250	2145
									15/1,0	3280	2810	2680	2565	2450
									17/1,2	3685	3160	3010	2880	2750
									20/1,4	4085	3500	3340	3200	3050
									23/1,6	4490	3850	3670	3515	3350
580/70 R38	TL	155 D	W18L	W18L, DW18L	577	1827	5463	819	9/0,6	2860	2450	2330	2240	2135
									12/0,8	3325	2850	2715	2605	2480
									15/1,0	3795	3250	3095	2970	2830
									17/1,2	4260	3650	3475	3340	3180
									20/1,4	4730	4055	3860	3700	3530
									23/1,6	5195	4455	4240	4070	3875
580/70 R42	TL	158 D/161 A8	W18L	DW18L	577	1879	5637	859	9/0,6	3135	2690	2560	2450	2340
									12/0,8	3645	3130	2975	2855	2720
									15/1,0	4160	3570	3395	3255	3105
									17/1,2	4670	4010	3815	3655	3485
									20/1,4	5185	4450	4230	4060	3870
									23/1,6	5695	4890	4650	4460	4250

Load capacity on recommended speed and pressure is stated with dark colour.

DESCRIPTION

* For load capacity on various speed ratings, and inflation figures, please consult your sales representative.

** Load capacity on standard speed and weight

- Our company is entitled to make any change on any information in this catalogue, without further notice.
- This catalogue annuls all the previous catalogues
- All figures are for reference; our company is not responsible for printing errors.



TR-110 /80

Tractor Radial

PERFORMANCE INFORMATION

General purpose **R-1W** tractor radial tire.



FEATURES

Long service life / Durability

Special tread compound provides high level of resistance against wear and cuts.

Tread profile enhances durability to tread base fatigue.

High traction

Low rolling resistance leads to maximum fuel efficiency.

Unique tread design provides exceptional traction and ensures maximum performance.

Low soil compaction / Reduced slip

Wider footprint offers lower soil compaction.

Special structure improves flotation on soft terrains and ensures a comfortable ride at all operating conditions.

SIZES

260/80 R20 · 480/80 R38 · 480/80 R42 · VF480/80 R42 · 480/80 R46 · VF480/80 R46
480/80 R50 · VF480/80 R50

Tractor Radial · Characteristics of **TR-110/80**

Tire Size	TT/TL	Load/Speed Index	Rims		Inflated Dimensions (No Load)		Inflated Dimensions (W/ Load)		Inflation Pressure (psi/bar)	Load capacity per tire, kg				
			Recom (inch)	Permitted (inch)	Section Width (mm)	Outer Diameter (mm)	Dynamic Rolling Circumference (mm)	Static Loaded Radius (mm)		Speed, km/h				
										10	30	40	50	65
260/80 R20	TL	106 A8 / 103 B	W8	W8, W9, 9	258	924	2795	430	9 / 0,6	705	560	525	480	-
									12 / 0,8	815	655	610	555	-
									15 / 1,0	930	745	695	635	-
									17 / 1,2	1045	835	780	710	-
									20 / 1,4	1160	930	865	790	-
									23 / 1,6	1275	1020	950	875	-
480/80 R38	TL	149 A8 / 149 B	DW16L	DD16L, W16L, DW16A, W16A	479	1733	5199	790	9 / 0,6	2400	1915	1790	1790	-
									12 / 0,8	2790	2230	2080	2080	-
									15 / 1,0	3180	2540	2375	2375	-
									17 / 1,2	3575	2855	2665	2665	-
									20 / 1,4	3965	3165	2960	2960	-
									23 / 1,6	4355	3480	3250	3250	-
480/80 R42	TL	151 A8 / 151 B	DW16L	DD16L, W16L, DW16A, W16A	479	1847.1	5538	846	9 / 0,6	2545	2035	1900	1900	-
									12 / 0,8	2960	2365	2210	2210	-
									15 / 1,0	3375	2695	2520	2520	-
									17 / 1,2	3795	3030	2830	2830	-
									20 / 1,4	4210	3360	3140	3140	-
									23 / 1,6	4625	3695	3450	3450	-
VF480/80 R42	TL	162 D	DW16L	DW15L, DW16L	479	1835	5538	846	9 / 0,6	2990	2565	2445	2345	2230
									12 / 0,8	3440	2950	2810	2695	2565
									15 / 1,0	3945	3385	3220	3090	2945
									17 / 1,2	4455	3820	3640	3490	3325
									20 / 1,4	4965	4260	4055	3890	3705
									23 / 1,6	5470	4695	4470	4290	4085
									26 / 1,8	6365	5460	5200	4990	4750

Load capacity on recommended speed and pressure is stated with dark colour.

DESCRIPTION

- * For load capacity on various speed ratings, and inflation figures, please consult your sales representative.
- ** Load capacity on standard speed and weight
- Our company is entitled to make any change on any information in this catalogue, without further notice.
- This catalogue annuls all the previous catalogues
- All figures are for reference; our company is not responsible for printing errors.

Tractor Radial · Characteristics of **TR-110/80**

Tire Size	TT/TL	Load/Speed Index	Rims		Inflated Dimensions (No Load)		Inflated Dimensions (W/ Load)		Inflation Pressure (psi/bar)	Load capacity per tire, kg				
			Recom (inch)	Permitted (inch)	Section Width (mm)	Outer Diameter (mm)	Dynamic Rolling Circumference (mm)	Static Loaded Radius (mm)		Speed, km/h				
										10	30	40	50	65
480/80 R46	TL	158 A8 / 158 B	DW16L	DD16L, W16L, DW16A, W16A	479	1952	5876	891	9/0,6	2680	2140	2000	2000	-
									12/0,8	3080	2460	2295	2295	-
									15/1,0	3535	2820	2635	2635	-
									17/1,2	3990	3185	2975	2975	-
									20/1,4	4445	3550	3315	3315	-
									23/1,6	4900	3915	3655	3655	-
									26/1,8	5130	4095	3825	3825	-
									29/2,0	5355	4275	3995	3995	-
									32/2,2	5525	4415	4125	4125	-
35/2,4	5695	4550	4250	4250	-									
VF480/80 R46	TL	177 D	DW16L	DW15L, DW16L	479	1936	5740	890	9/0,6	3620	3240	2950	2835	2700
									12/0,8	4205	3770	3435	3295	3140
									15/1,0	4790	4290	3915	3755	3580
									17/1,2	5475	4905	4475	4290	4090
									20/1,4	6060	5430	4950	4750	4530
									23/1,6	6650	5960	5430	5210	4965
									26/1,8	6990	6265	5710	5480	5220
									29/2,0	7335	6570	5990	5750	5475
									32/2,2	7530	6745	6150	5900	5620
									35/2,4	7730	6920	6310	6055	5765
									38/2,6	8120	7270	6630	6360	6060
									41/2,8	8510	7620	6950	6670	6350
									44/3,0	8850	7925	7230	6940	6600
									46/3,2	9190	8230	7510	7205	6860
49/3,4	9485	8495	7750	7435	7080									
52/3,6	9780	8760	7990	7665	7300									
480/80 R50	TL	159 A8 / 159 B	DW16L	DW14L-W15L, DW15L-W16L	479	2064	6192	945	9/0,6	2760	2205	2060	2060	-
									12/0,8	3170	2530	2365	2365	-
									15/1,0	3635	2905	2715	2715	-
									17/1,2	4105	3280	3065	3065	-
									20/1,4	4575	3655	3415	3415	-
									23/1,6	5045	4030	3765	3765	-
									26/1,8	5280	4215	3940	3940	-
									29/2,0	5515	4405	4115	4115	-
									32/2,2	5690	4545	4245	4245	-
35/2,4	5865	4685	4375	4375	-									

Load capacity on recommended speed and pressure is stated with dark colour.

Tractor Radial · Characteristics of **TR-110/80**

Tire Size	TT/TL	Load/Speed Index	Rims		Inflated Dimensions (No Load)		Inflated Dimensions (W/ Load)		Inflation Pressure (psi/bar)	Load capacity per tire, kg				
			Recom (inch)	Permitted (inch)	Section Width (mm)	Outer Diameter (mm)	Dynamic Rolling Circumference (mm)	Static Loaded Radius (mm)		Speed, km/h				
										10	30	40	50	65
VF480/80 R50	TL	179 D	DW16L	DW15L, DW16	479	2038	6100	940	9 / 0,6	3840	3300	3140	3010	2865
									12 / 0,8	4465	3830	3645	3500	3330
									15 / 1,0	5090	4365	4155	3990	3800
									17 / 1,2	5815	4990	4750	4555	4340
									20 / 1,4	6440	5525	5260	5045	4805
									23 / 1,6	7060	6060	5765	5530	5270
									26 / 1,8	7425	6370	6065	5815	5540
									29 / 2,0	7790	6680	6360	6100	5810
									32 / 2,2	7995	6860	6530	6260	5965
									35 / 2,4	8200	7040	6700	6425	6120
									38 / 2,6	8620	7395	7040	6750	6430
									41 / 2,8	9035	7750	7380	7075	6740
									44 / 3,0	9400	8065	7675	7360	7015
									46 / 3,2	9760	8375	7970	7645	7285
									49 / 3,4	10075	8640	8225	7890	7520
52 / 3,6	10385	8910	8480	8135	7750									

Load capacity on recommended speed and pressure is stated with dark colour.

DESCRIPTION

* For load capacity on various speed ratings, and inflation figures, please consult your sales representative.

** Load capacity on standard speed and weight

- Our company is entitled to make any change on any information in this catalogue, without further notice.
- This catalogue annuls all the previous catalogues
- All figures are for reference; our company is not responsible for printing errors.



TR-110/85

Tractor Radial

PERFORMANCE INFORMATION

General purpose **R-1W** tractor radial tire.



FEATURES

Long service life / Durability

Special tread compound provides high level of resistance against wear and cuts.

Tread profile enhances durability to tread base fatigue.

High traction

Low rolling resistance leads to maximum fuel efficiency.

Unique tread design provides exceptional traction and ensures maximum performance.

Low soil compaction / Reduced slip

Wider footprint offers lower soil compaction.

Special structure improves flotation on soft terrains and ensures a comfortable ride at all operating conditions.

SIZES

9.5 R20 · 9.5 R24 · 280/85 R20 · 320/85 R20 · 280/85 R24 · 320/85 R24 · 340/85 R24 · 380/85 R24 · 420/85 R24 · 280/85 R28 · 320/85 R28 · 340/85 R28 · 380/85 R28 · 420/85 R28 · 380/85 R30 · 420/85 R30 · 460/85 R30 · 320/85 R32 · 380/85 R34 · 420/85 R34 · 460/85 R34 · 320/85 R36 · 340/85 R36 · 320/85 R38 · 340/85 R38 · 380/85 R38 · 420/85 R38 · 460/85 R38 · 460/85 R38 RF · 520/85 R38 · 520/85 R38 RF · 520/85 R42 · 520/85 R42 RF · 520/85 R46 · VF520/85 R46

Tractor Radial · Characteristics of **TR-110/85**

Tire Size	TT/TL	Load/Speed Index	Rims		Inflated Dimensions (No Load)		Inflated Dimensions (W/Load)		Inflation Pressure (psi/bar)	Load capacity per tire, kg			
			Recom (inch)	Permitted (inch)	Section Width (mm)	Outer Diameter (mm)	Dynamic Rolling Circumference (mm)	Static Loaded Radius (mm)		Speed, km/h			
										10	30	40	50
9.5 R20	TL	108 A8 / 105 B	W8	W7	241	940	2848	430	9/0.6	740	590	550	505
									12/0.8	860	685	640	585
									15/1.0	980	785	730	665
									17/1.2	1100	880	820	750
									20/1.4	1220	975	910	830
									23/1.6	1340	1070	1000	925
9.5 R24	TL	107 A8 / 104 B	W8	W7	241	1030	3135	488	9/0.6	720	575	540	490
									12/0.8	840	670	625	570
									15/1.0	955	765	715	650
									17/1.2	1075	860	800	730
									20/1.4	1190	950	890	810
									23/1.6	1310	1045	975	900
280/85 R20	TL	112 A8 / 109 B	W10	W9	282	989	2955	446	9/0.6	830	660	620	565
									12/0.8	965	770	720	655
									15/1.0	1100	875	820	745
									17/1.2	1235	985	920	840
									20/1.4	1370	1095	1020	930
									23/1.6	1505	1200	1120	1030
320/85 R20	TL	119 A8 / 116 B	W11	W9-W10	319	1052	3145	472	9/0.6	1005	805	750	685
									12/0.8	1170	935	875	795
									15/1.0	1335	1065	995	905
									17/1.2	1495	1195	1120	1015
									20/1.4	1660	1325	1240	1130
									23/1.6	1825	1460	1360	1250

Load capacity on recommended speed and pressure is stated with dark colour.

DESCRIPTION

* For load capacity on various speed ratings, and inflation figures, please consult your sales representative.

** Load capacity on standard speed and weight

- Our company is entitled to make any change on any information in this catalogue, without further notice.
- This catalogue annuls all the previous catalogues
- All figures are for reference; our company is not responsible for printing errors.

Tractor Radial · Characteristics of **TR-110/85**

Tire Size	TT/TL	Load/Speed Index	Rims		Inflated Dimensions (No Load)		Inflated Dimensions (W/Load)		Inflation Pressure (psi/bar)	Load capacity per tire, kg			
			Recom (inch)	Permitted (inch)	Section Width (mm)	Outer Diameter (mm)	Dynamic Rolling Circumference (mm)	Static Loaded Radius (mm)		Speed, km/h			
										10	30	40	50
280/85 R24	TL	115 A8/ 112 B	W10	W9	282	1086	3267	495	9/0.6	900	720	670	610
									12/0.8	1045	835	780	710
									15/1.0	1190	950	890	810
									17/1.2	1340	1070	1000	910
									20/1.4	1485	1185	1110	1010
									23/1.6	1630	1305	1215	1120
320/85 R24	TL	122 A8/ 122 B	W11	W9-W10	319	1154	3465	515	9/0.6	1110	885	825	825
									12/0.8	1290	1030	960	960
									15/1.0	1470	1175	1095	1095
									17/1.2	1650	1320	1230	1230
									20/1.4	1830	1465	1365	1365
									23/1.6	2010	1605	1500	1500
340/85 R24	TL	125 A8/ 125 B	W12	W11, DW11, DW12	343	1188	3555	542	9/0.6	1220	975	910	910
									12/0.8	1420	1130	1060	1060
									15/1.0	1615	1290	1205	1205
									17/1.2	1815	1450	1355	1355
									20/1.4	2015	1610	1505	1505
									23/1.6	2215	1770	1650	1650
380/85 R24	TL	131 A8/ 131 B	W12	W11, DW11, DW12, W13, DW13	380	1256	3750	560	9/0.6	1440	1150	1075	1075
									12/0.8	1675	1340	1250	1250
									15/1.0	1910	1525	1425	1425
									17/1.2	2145	1715	1600	1600
									20/1.4	2380	1900	1775	1775
									23/1.6	2615	2090	1950	1950
420/85 R24	TL	137 A8/ 137 B	W15L	W13, DW13, W14L, DW14, DW15	418	1324	3958	591	9/0.6	1700	1355	1265	1265
									12/0.8	1975	1580	1475	1475
									15/1.0	2250	1800	1680	1680
									17/1.2	2530	2020	1890	1890
									20/1.4	2805	2240	2095	2095
									23/1.6	3085	2465	2300	2300

Load capacity on recommended speed and pressure is stated with dark colour.

DESCRIPTION

* For load capacity on various speed ratings, and inflation figures, please consult your sales representative.

** Load capacity on standard speed and weight

- Our company is entitled to make any change on any information in this catalogue, without further notice.
- This catalogue annuls all the previous catalogues
- All figures are for reference; our company is not responsible for printing errors.



Tractor Radial · Characteristics of **TR-110/85**

Tire Size	TT/TL	Load/Speed Index	Rims		Inflated Dimensions (No Load)		Inflated Dimensions (W/Load)		Inflation Pressure (psi/bar)	Load capacity per tire, kg			
			Recom (inch)	Permitted (inch)	Section Width (mm)	Outer Diameter (mm)	Dynamic Rolling Circumference (mm)	Static Loaded Radius (mm)		Speed, km/h			
										10	30	40	50
280/85 R28	TL	118 A8 / 118 B	W10	W9, DW10	282	1186.6	3560	542	9 / 0.6	975	780	730	730
									12 / 0.8	1135	905	845	845
									15 / 1.0	1295	1035	965	965
									17 / 1.2	1455	1160	1085	1085
									20 / 1.4	1610	1290	1205	1205
									23 / 1.6	1770	1415	1320	1320
320/85 R28	TL	124 A8 / 124 B	W11	W9, W10, DW10, DW11	319	1255	3752	574	9 / 0.6	1180	945	880	880
									12 / 0.8	1375	1100	1025	1025
									15 / 1.0	1570	1250	1170	1170
									17 / 1.2	1760	1405	1315	1315
									20 / 1.4	1955	1560	1460	1460
									23 / 1.6	2145	1715	1600	1600
340/85 R28	TL	127 A8 / 127 B	W12	W11, DW11, DW12	360	1289	3880	600	9 / 0.6	1290	1030	965	965
									12 / 0.8	1505	1200	1120	1120
									15 / 1.0	1715	1370	1280	1280
									17 / 1.2	1925	1540	1435	1435
									20 / 1.4	2135	1705	1595	1595
									23 / 1.6	2345	1875	1750	1750
380/85 R28	TL	133 A8 / 133 B	W12	W11, DW11, W12, DW12, W13	380	1350	4089	612	9 / 0.6	1520	1215	1135	1135
									12 / 0.8	1770	1415	1320	1320
									15 / 1.0	2020	1610	1505	1505
									17 / 1.2	2265	1810	1690	1690
									20 / 1.4	2515	2010	1875	1875
									23 / 1.6	2765	2205	2060	2060

Load capacity on recommended speed and pressure is stated with dark colour.

DESCRIPTION

* For load capacity on various speed ratings, and inflation figures, please consult your sales representative.

** Load capacity on standard speed and weight

- Our company is entitled to make any change on any information in this catalogue, without further notice.
- This catalogue annuls all the previous catalogues
- All figures are for reference; our company is not responsible for printing errors.



Tractor Radial · Characteristics of **TR-110/85**

Tire Size	TT/TL	Load/Speed Index	Rims		Inflated Dimensions (No Load)		Inflated Dimensions (W/Load)		Inflation Pressure (psi/bar)	Load capacity per tire, kg			
			Recom (inch)	Permitted (inch)	Section Width (mm)	Outer Diameter (mm)	Dynamic Rolling Circumference (mm)	Static Loaded Radius (mm)		Speed, km/h			
										10	30	40	50
420/85 R28	TL	139 A8 / 139 B	W15L	W13, DW13, W14L, DW14L, W15, DW15L	418	1425	4261	635	9/0.6	1795	1435	1340	1340
									12/0.8	2085	1665	1560	1560
									15/1.0	2380	1900	1775	1775
									17/1.2	2675	2135	1995	1995
									20/1.4	2965	2370	2215	2215
									23/1.6	3260	2605	2430	2430
380/85 R30	TL	135 A8 / 135 B	W12	W11, W13	380	1408	4236	634	9/0.6	1610	1285	1200	1200
									12/0.8	1870	1495	1400	1400
									15/1.0	2135	1705	1595	1595
									17/1.2	2400	1915	1790	1790
									20/1.4	2660	2125	1985	1985
									23/1.6	2925	2335	2180	2180
420/85 R30	TL	140 A8 / 140 B	W15L	W13, DW13L, W14L, DW14L, W15L, DW15L	418	1475	4455	660	9/0.6	1845	1475	1375	1375
									12/0.8	2145	1715	1600	1600
									15/1.0	2450	1955	1825	1825
									17/1.2	2750	2195	2050	2050
									20/1.4	3050	2435	2275	2275
									23/1.6	3350	2675	2500	2500
460/85 R30 RF	TL	145 A8 / 145 B	DW15	W14L, W15L, DW15L, W16L, DW16L	455	1544	4683	694	9/0.6	2140	1710	1595	1595
									12/0.8	2490	1990	1860	1860
									15/1.0	2840	2270	2120	2120
									17/1.2	3190	2545	2380	2380
									20/1.4	3540	2825	2640	2640
									23/1.6	3890	3105	2900	2900

Load capacity on recommended speed and pressure is stated with dark colour.

RF: REINFORCED

DESCRIPTION

* For load capacity on various speed ratings, and inflation figures, please consult your sales representative.

** Load capacity on standard speed and weight

- Our company is entitled to make any change on any information in this catalogue, without further notice.
- This catalogue annuls all the previous catalogues
- All figures are for reference; our company is not responsible for printing errors.

Tractor Radial · Characteristics of **TR-110/85**

Tire Size	TT/TL	Load/Speed Index	Rims		Inflated Dimensions (No Load)		Inflated Dimensions (W/Load)		Inflation Pressure (psi/bar)	Load capacity per tire, kg			
			Recom (inch)	Permitted (inch)	Section Width (mm)	Outer Diameter (mm)	Dynamic Rolling Circumference (mm)	Static Loaded Radius (mm)		Speed, km/h			
										10	30	40	50
320/85 R32	TL	126 A8/ 126 B	W11	W9, W10	319	1357	4071	625	9/0.6	1255	1005	935	935
									12/0.8	1460	1165	1090	1090
									15/1.0	1665	1330	1245	1245
									17/1.2	1870	1495	1395	1395
									20/1.4	2075	1660	1550	1550
									23/1.6	2280	1820	1700	1700
380/85 R34	TL	137 A8/ 137 B	W12	W11-W13	380	1528	4468	674	9/0.6	1700	1355	1265	1265
									12/0.8	1975	1580	1475	1475
									15/1.0	2250	1800	1680	1680
									17/1.2	2530	2020	1890	1890
									20/1.4	2805	2240	2095	2095
									23/1.6	3085	2465	2300	2300
420/85 R34	TL	142 A8/ 142 B	W15L	W13, DW13L, W14L, DW14L, W15L, DW15L	418	1578	4750	715	9/0.6	1955	1560	1460	1460
									12/0.8	2275	1815	1700	1700
									15/1.0	2595	2070	1935	1935
									17/1.2	2915	2330	2175	2175
									20/1.4	3235	2585	2415	2415
									23/1.6	3555	2840	2650	2650
460/85 R34	TL	147 A8/ 144 B	W16L	W14L- W15L	455	1646	4965	750	9/0.6	2270	1810	1695	1540
									12/0.8	2640	2110	1970	1795
									15/1.0	3010	2405	2245	2045
									17/1.2	3380	2700	2525	2295
									20/1.4	3750	2995	2800	2550
									23/1.6	4125	3295	3075	2800

Load capacity on recommended speed and pressure is stated with dark colour.

DESCRIPTION

* For load capacity on various speed ratings, and inflation figures, please consult your sales representative.

** Load capacity on standard speed and weight

- Our company is entitled to make any change on any information in this catalogue, without further notice.
- This catalogue annuls all the previous catalogues
- All figures are for reference; our company is not responsible for printing errors.



Tractor Radial · Characteristics of **TR-110/85**

Tire Size	TT/TL	Load/Speed Index	Rims		Inflated Dimensions (No Load)		Inflated Dimensions (W/Load)		Inflation Pressure (psi/bar)	Load capacity per tire, kg			
			Recom (inch)	Permitted (inch)	Section Width (mm)	Outer Diameter (mm)	Dynamic Rolling Circumference (mm)	Static Loaded Radius (mm)		Speed, km/h			
										10	30	40	50
320/85 R36	TL	128 A8 / 125 B	W11	W9-W10	319	1458	4364	671	9/0.6	1330	1060	990	905
									12/0.8	1545	1235	1155	1050
									15/1.0	1765	1410	1315	1200
									17/1.2	1980	1580	1480	1345
									20/1.4	2195	1755	1640	1495
									23/1.6	2415	1930	1800	1650
340/85 R36	TL	132 A8 / 132 B	W12	W11, DW11, W12, DW12	343	1492	4482	685	9/0.6	1475	1180	1100	1100
									12/0.8	1720	1370	1280	1280
									15/1.0	1960	1565	1460	1460
									17/1.2	2200	1755	1640	1640
									20/1.4	2440	1950	1820	1820
									23/1.6	2680	2140	2000	2000
320/85 R38	TL	143 A8 / 143 B	W10	W9, W10, DW10, W11, DW11	319	1509	4515	698	9/0,6	1510	1080	1060	1060
									12/0,8	1755	1250	1170	1170
									15/1,0	2000	1428	1335	1335
									17/1,2	2290	1630	1525	1525
									20/1,4	2535	1805	1690	1690
									23/1,6	2780	1980	1855	1855
									26/1,8	2920	2080	1950	1950
									29/2,0	3065	2185	2045	2045
									32/2,2	3145	2240	2100	2100
									35/2,4	3225	2300	2150	2150
									38/2,6	3390	2415	2260	2260
									41/2,8	3555	2535	2370	2370
									44/3,0	3700	2635	2465	2465
									46/3,2	3840	2740	2560	2560
49/3,4	3960	2830	2640	2640									
52/3,6	4085	2915	2725	2725									
340/85 R38	TL	133 A8 / 130 B	W12	W11	343	1540	4675	715	9/0.6	1520	1215	1135	1035
									12/0.8	1770	1415	1320	1200
									15/1.0	2020	1610	1505	1370
									17/1.2	2265	1810	1690	1540
									20/1.4	2515	2010	1875	1710
									23/1.6	2765	2205	2060	1900

Load capacity on recommended speed and pressure is stated with dark colour.

Tractor Radial · Characteristics of **TR-110/85**

Tire Size	TT/TL	Load/Speed Index	Rims		Inflated Dimensions (No Load)		Inflated Dimensions (W/Load)		Inflation Pressure (psi/bar)	Load capacity per tire, kg			
			Recom (inch)	Permitted (inch)	Section Width (mm)	Outer Diameter (mm)	Dynamic Rolling Circumference (mm)	Static Loaded Radius (mm)		Speed, km/h			
										10	30	40	50
380/85 R38	TL	139 A8 / 139 B	W12	W11-W13	380	1611	4833	742	9/0.6	1795	1435	1340	1340
									12/0.8	2085	1665	1560	1560
									15/1.0	2380	1900	1775	1775
									17/1.2	2675	2135	1995	1995
									20/1.4	2965	2370	2215	2215
									23/1.6	3260	2605	2430	2430
420/85 R38	TL	144 A8 / 144 B	W15L	W13, DW13L, W14L, DW14L, W15L, DW15L	418	1675	5042	762	9/0.6	2065	1650	1540	1540
									12/0.8	2405	1920	1795	1795
									15/1.0	2740	2190	2045	2045
									17/1.2	3080	2460	2300	2300
									20/1.4	3415	2730	2550	2550
									23/1.6	3755	3000	2800	2800
460/85 R38	TL	149 A8 / 146 B	W16L	W14L, W15L	455	1747	5270	805	9/0.6	2400	1915	1790	1630
									12/0.8	2790	2230	2080	1895
									15/1.0	3180	2540	2375	2160
									17/1.2	3575	2855	2665	2430
									20/1.4	3965	3165	2960	2695
									23/1.6	4355	3480	3250	3000
460/85 R38 RF	TL	149 A8 / 149 B	DW15L	W14L, W15L, W16L	455	1747	5270	805	9/0,6	2400	2070	1950	1790
									12/0,8	2790	2410	2265	2080
									15/1,0	3180	2750	2585	2375
									17/1,2	3575	3090	2900	2665
									20/1,4	3965	3430	3220	2960
									23/1,6	4355	3770	3540	3250

Load capacity on recommended speed and pressure is stated with dark colour.

DESCRIPTION

* For load capacity on various speed ratings, and inflation figures, please consult your sales representative.

** Load capacity on standard speed and weight

- Our company is entitled to make any change on any information in this catalogue, without further notice.
- This catalogue annuls all the previous catalogues
- All figures are for reference; our company is not responsible for printing errors.

Tractor Radial · Characteristics of **TR-110/85**

Tire Size	TT/TL	Load/Speed Index	Rims		Inflated Dimensions (No Load)		Inflated Dimensions (W/Load)		Inflation Pressure (psi/bar)	Load capacity per tire, kg			
			Recom (inch)	Permitted (inch)	Section Width (mm)	Outer Diameter (mm)	Dynamic Rolling Circumference (mm)	Static Loaded Radius (mm)		Speed, km/h			
										10	30	40	50
520/85 R38	TL	155 A8 / 152 B	W15L, W16L, DW16L	DD16L, W18L, DW18L, DD18L	516	1849	5529	828	9 / 0,6	2860	2285	2135	1940
									12 / 0,8	3325	2655	2480	2260
									15 / 1,0	3795	3030	2830	2575
									17 / 1,2	4260	3400	3180	2895
									20 / 1,4	4730	3775	3530	3210
									23 / 1,6	5195	4150	3875	3550
520/85 R38 RF	TL	172 A8 / 172 B	DW16L	DW15L, DD16L, W18L, DW18L, DD18L	516	1849	5540	856	17 / 1,2	5050	3770	3530	3530
									20 / 1,4	5595	4175	3900	3900
									23 / 1,6	6140	4580	4285	4285
									26 / 1,8	6455	4810	4500	4500
									29 / 2,0	6770	5055	4725	4725
									32 / 2,2	6950	5185	4850	4850
									35 / 2,4	7130	5320	4980	4980
									38 / 2,6	7490	5590	5230	5230
									41 / 2,8	7855	5860	5480	5480
									44 / 3,0	8235	6145	5740	5740
									46 / 3,2	8490	6335	5920	5920
									49 / 3,4	8760	6530	6110	6110
52 / 3,6	9030	6740	6300	6300									
520/85 R42	TL	157 A8 / 157 B	DD18L	DW16L, DW18L	516	1951	5850	875	9 / 0,6	1700	1355	1265	1265
									12 / 0,8	1975	1580	1475	1475
									15 / 1,0	2250	1800	1680	1680
									17 / 1,2	2530	2020	1890	1890
									20 / 1,4	2805	2240	2095	2095
									23 / 1,6	5530	4415	4125	4125
520/85 R42 RF	TL	162 A8 / 162 B	DW16L	W15, DW15, W16, DW16L, W18, DW18L	516	1951	5850	875	9 / 0,6	2990	2385	2230	2230
									12 / 0,8	3435	2740	2565	2565
									15 / 1,0	3945	3275	2945	2945
									17 / 1,2	4455	3555	3325	3325
									20 / 1,4	4960	3960	3705	3705
									23 / 1,6	5470	4365	4085	4085
									26 / 1,8	5725	4570	4275	4275
									29 / 2,0	5980	4775	4465	4465
									32 / 2,2	6170	4930	4605	4605
									35 / 2,4	6365	5080	4750	4750

Load capacity on recommended speed and pressure is stated with dark colour.

Tractor Radial · Characteristics of **TR-110/85**

Tire Size	TT/TL	Load/Speed Index	Rims		Inflated Dimensions (No Load)		Inflated Dimensions (W/ Load)		Inflation Pressure (psi/bar)	Load capacity per tire, kg				
			Recom (inch)	Permitted (inch)	Section Width (mm)	Outer Diameter (mm)	Dynamic Rolling Circumference (mm)	Static Loaded Radius (mm)		Speed, km/h				
										10	30	40	50	65
VF520/85 R42 RF	TL	174 D / 177 A8	DW18L	DW16L, DW18L	516	1951	5850	875	15 / 1,0	5575	4450	4160	4010	3820
									17 / 1,2	6260	5000	4670	4500	4290
									20 / 1,4	6940	5545	5180	5000	4760
									23 / 1,6	7630	6090	5690	5490	5230
									26 / 1,8	8020	6405	5985	5770	5495
									29 / 2,0	8410	6720	6280	6050	5760
									32 / 2,2	8655	6910	6460	6225	5930
									35 / 2,4	8900	7100	6640	6400	6100
									38 / 2,6	9340	7455	6970	6720	6400
								41 / 2,8	9780	7810	7300	7035	6700	
520/85 R46	TL	158 A8 / 155 B	DW16L	DW18L	516	2052	6090	922	9 / 0,6	3135	2505	2340	2130	-
									12 / 0,8	3645	2915	2720	2480	-
									15 / 1,0	4160	3320	3105	2825	-
									17 / 1,2	4670	3730	3485	3175	-
									20 / 1,4	5185	4140	3870	3520	-
									23 / 1,6	5695	4550	4250	3875	-
VF520/85 R46	TL	170 D	DW18L	DW18L	526	2052	6030	900	9 / 0,6	3630	3365	3300	3300	3300
									12 / 0,8	4220	3915	3840	3840	3840
									15 / 1,0	4820	4465	4380	4380	4380
									17 / 1,2	5410	5020	4920	4920	4920
									20 / 1,4	6005	5570	5460	5460	5460
									23 / 1,6	6600	6120	6000	6000	6000

Load capacity on recommended speed and pressure is stated with dark colour.

RF: REINFORCED

VF: VERY HIGH FLEXION

DESCRIPTION

* For load capacity on various speed ratings, and inflation figures, please consult your sales representative.

** Load capacity on standard speed and weight

- Our company is entitled to make any change on any information in this catalogue, without further notice.
- This catalogue annuls all the previous catalogues
- All figures are for reference; our company is not responsible for printing errors.



TR-110 PLUS

PERFORMANCE INFORMATION

Radial farm tire with its unique compound.



FEATURES

Traction

Special tread geometry improves traction and reduces slipping, resulting in significant fuel savings.

Provides excellent traction with optimized pattern of angles on the tread.

Wear Resistance

Resistance against wear and cracks due to its more robust structure in the tread grooves and its unique mixture.

SIZES 650/65 R38

Tractor Radial · Characteristics of **TR-110 PLUS**

Tire Size	TT/TL	Load/Speed Index	Rims		Inflated Dimensions (No Load)		Inflated Dimensions (W/ Load)		Inflation Pressure (psi/bar)	Load capacity per tire, kg				
			Recom (inch)	Permitted (inch)	Section Width (mm)	Outer Diameter (mm)	Dynamic Rolling Circumference (mm)	Static Loaded Radius (mm)		Speed, km/h				
										10	30	40	50	65
650/65 R38	TL	171 D / 174 A8	DW20B	DW20B, DW21B, DW23B	645	1841	5430	845	17,4 / 1,2	5165	3960	3750	3615	3440
									20,3 / 1,4	5715	4380	4150	4000	3810
									23,2 / 1,6	6270	4800	4555	4390	4180
									26,1 / 1,8	6595	5050	4790	4615	4395
									29 / 2	6920	5300	5025	4840	4610
									31,9 / 2,2	7100	5440	5160	4970	4735
									34,8 / 2,4	7285	5585	5290	5100	4860
									37,7 / 2,6	7655	5870	5560	5360	5100
									40,6 / 2,8	8025	6150	5830	5615	5350
									43,5 / 3	8410	6450	6110	5885	5610
									46,4 / 3,2	8670	6645	6300	6065	5780
49,3 / 3,4	8950	6855	6500	6260	5965									
52,2 / 3,6	9225	7070	6700	6455	6150									
650/65 R38	TL	163 D / 166 A8	DW23B	DW20B, DW21B	645	2071	6095	922	9 / 0,6	4095	3270	3055	3055	-
									12 / 0,8	4705	3760	3510	3510	-
									15 / 1	5405	4315	4030	4030	-
									17 / 1,2	6100	4870	4550	4550	-
									20 / 1,4	6795	5425	5070	5070	-
									23 / 1,6	7495	5985	5590	5590	-
									26 / 1,8	7840	6260	5850	5850	-
									29 / 2	8190	6540	6110	6110	-
									32 / 2,2	8450	6750	6305	6305	-
									35 / 2,4	8710	6955	6500	6500	-
650/65 R38	TL	173 D	DW23B	DW20B, DW21B	645	2071	6095	922	8,7 / 0,6	4090	3510	3345	3210	3055
									11,6 / 0,8	4700	4035	3845	3685	3510
									14,5 / 1	5400	4635	4410	4230	4030
									17,4 / 1,2	6100	5230	4985	4780	4550
									20,3 / 1,4	6790	5830	5550	5320	5070
									23,2 / 1,6	7490	6430	6120	5870	5590
									26,1 / 1,8	7840	6730	6405	6140	5850
									29 / 2	8190	7025	6690	6415	6110
									31,9 / 2,2	8450	7250	6905	6620	6305
									34,8 / 2,4	8710	7475	7120	6825	6500

Load capacity on recommended speed and pressure is stated with dark colour.

DESCRIPTION

* For load capacity on various speed ratings, and inflation figures, please consult your sales representative.

** Load capacity on standard speed and weight

- Our company is entitled to make any change on any information in this catalogue, without further notice.
- This catalogue annuls all the previous catalogues
- All figures are for reference; our company is not responsible for printing errors.



TR-120 Row Crop

PERFORMANCE INFORMATION

General purpose **R-1W** row crop tractor and sprayer tire.



FEATURES

Long service life / Durability

Deep lugs and special tread compound ensure longevity.

Special tread compound provides high resistance against wear and cuts.

Narrow profile / Crop protection

Narrow profile protects the crop from damages.

High traction / Heavy load

Robust carcass structure enables maximum performance under heavy loads.

SIZES

210/95 R32 · 230/95 R32 · 270/95 R32 · 210/95 R36 · 230/95 R36 · 270/95 R36 · 270/95 R38 · 230/95 R40
210/95 R44 · 230/95 R44 · 270/95 R44 · 270/95 R46 · 300/95 R46 · VF320/90 R46 · 230/95 R48
270/95 R48 · 300/95 R52 · 270/95 R54 · 380/90 R46 · VF380/90 R46 · 340/85 R46 · 340/85 R48

Tractor Radial · Characteristics of **TR-120**

Tire Size	TT/TL	Load/Speed Index	Rims		Inflated Dimensions (No Load)		Inflated Dimensions (W/Load)		Inflation Pressure (psi/bar)	Load capacity per tire, kg					
			Recom (inch)	Permitted (inch)	Section Width (mm)	Outer Diameter (mm)	Dynamic Rolling Circumference (mm)	Static Loaded Radius (mm)		Speed, km/h					
										10	25	30	40	50	65
210/95 R32	TL	120 A8/120 B	W7	W6	214	1213	3639	567	9/0,6	730	605	585	545	545	-
									12/0,8	865	715	690	645	645	-
									15/1,0	995	825	795	740	740	-
									17/1,2	1105	915	885	825	825	-
									20/1,4	1240	1015	990	925	925	-
									23/1,6	1350	1120	1080	1010	1010	-
									26/1,8	1415	1175	1135	1060	1060	-
									29/2,0	1480	1230	1185	1105	1105	-
									32/2,2	1540	1275	1230	1150	1150	-
									35/2,4	1595	1320	1275	1190	1190	-
									38/2,6	1670	1380	1335	1245	1245	-
									41/2,8	1745	1445	1395	1300	1300	-
44/3,0	1810	1500	1450	1350	1350	-									
								46/3,2	1875	1555	1500	1400	1400	-	
230/95 R32	TL	128 D/131 A8	W7	W8	228	1251	3799	593	17/1,2	1385	1145	1105	1035	1000	954
									20/1,4	1530	1260	1220	1140	1105	1050
									23/1,6	1670	1380	1335	1250	1210	1152
									26/1,8	1760	1455	1410	1315	1275	1215
									29/2,0	1850	1530	1480	1385	1340	1280
									32/2,2	1905	1575	1520	1420	1375	1315
									35/2,4	1960	1620	1560	1460	1415	1350
									38/2,6	2050	1695	1635	1530	1480	1410
									41/2,8	2140	1770	1710	1600	1550	1475
									44/3,0	2250	1860	1800	1685	1630	1550
									46/3,2	2320	1920	1855	1735	1680	1600
									49/3,4	2400	1985	1915	1790	1735	1655
52/3,6	2480	2050	1980	1850	1795	1710									
								58/4,0	2610	2160	2085	1950	1890	1800	

Load capacity on recommended speed and pressure is stated with dark colour.

DESCRIPTION

- * For load capacity on various speed ratings, and inflation figures, please consult your sales representative.
- ** Load capacity on standard speed and weight

- Our company is entitled to make any change on any information in this catalogue, without further notice.
- This catalogue annuls all the previous catalogues
- All figures are for reference; our company is not responsible for printing errors.

Tractor Radial · Characteristics of **TR-120**

Tire Size	TT/TL	Load/Speed Index	Rims		Inflated Dimensions (No Load)		Inflated Dimensions (W/Load)		Inflation Pressure (psi/bar)	Load capacity per tire, kg					
			Recom (inch)	Permitted (inch)	Section Width (mm)	Outer Diameter (mm)	Dynamic Rolling Circumference (mm)	Static Loaded Radius (mm)		Speed, km/h					
										10	25	30	40	50	65
270/95 R32	TL	136 A8/ 136 B	W9	W8, W10	275	1327	3981	618	17/1,2	1595	1320	1275	1190	1190	-
									20/1,4	1775	1470	1415	1325	1325	-
									23/1,6	1925	1595	1535	1435	1435	-
									26/1,8	2045	1695	1630	1525	1525	-
									29/2,0	2135	1770	1705	1595	1595	-
									32/2,2	2195	1820	1750	1640	1640	-
									35/2,4	2255	1865	1800	1680	1680	-
									38/2,6	2375	1965	1895	1770	1770	-
									41/2,8	2465	2040	1970	1840	1840	-
									44/3,0	2555	2115	2040	1905	1905	-
									46/3,2	2675	2215	2135	1995	1995	-
									49/3,4	2765	2290	2210	2065	2065	-
									52/3,6	2855	2365	2280	2130	2130	-
55/3,8	2915	2415	2325	2175	2175	-									
58/4,0	3005	2490	2400	2240	2240	-									
210/95 R36	TL	118 D/ 121 A8	W7	W6	211	1314	3985	621	17/1,2	1360	1130	1085	1015	970	925
									20/1,4	1515	1255	1210	1130	1080	1030
									23/1,6	1670	1385	1330	1250	1190	1135
									26/1,8	1750	1450	1395	1305	1245	1190
									29/2,0	1825	1515	1460	1360	1300	1240
									32/2,2	1880	1560	1505	1405	1340	1280
									35/2,4	1940	1610	1550	1450	1385	1320
230/95 R36	TL	130 D/ 133 A8	W7	W8	228	1352	4117	644	17/1,2	1460	1285	1165	1090	1060	1005
									20/1,4	1630	1430	1300	1215	1180	1120
									23/1,6	1765	1550	1410	1315	1275	1215
									26/1,8	1860	1635	1485	1390	1345	1280
									29/2,0	1960	1720	1560	1460	1415	1350
									32/2,2	2070	1815	1650	1545	1495	1425
									35/2,4	2180	1915	1740	1630	1575	1500
									38/2,6	2220	1950	1770	1660	1605	1530
									41/2,8	2260	1990	1805	1690	1635	1560
									44/3,0	2380	2095	1900	1780	1720	1640
									46/3,2	2455	2160	1960	1830	1775	1690
									49/3,4	2540	2230	2025	1895	1835	1750
									52/3,6	2620	2300	2090	1960	1895	1805
58/4,0	2760	2425	2200	2060	1995	1900									

Load capacity on recommended speed and pressure is stated with dark colour.

Tractor Radial · Characteristics of **TR-120**

Tire Size	TT/ TL	Load/ Speed Index	Rims		Inflated Dimensions (No Load)		Inflated Dimensions (W/Load)		Inflation Pressure (psi/bar)	Load capacity per tire, kg					
			Recom (inch)	Permitted (inch)	Section Width (mm)	Outer Diameter (mm)	Dynamic Rolling Circumference (mm)	Static Loaded Radius (mm)		Speed, km/h					
										10	25	30	40	50	65
270/95 R36	TL	139 A8/ 136 D	W9	W8, W10	275	1428	4275	670	17 / 1,2	1780	1405	1365	1290	1245	1185
									20 / 1,4	1965	1550	1505	1420	1375	1310
									23 / 1,6	2150	1695	1645	1555	1505	1430
									26 / 1,8	2265	1790	1735	1640	1585	1510
									29 / 2,0	2385	1885	1825	1725	1670	1590
									32 / 2,2	2450	1935	1880	1770	1715	1635
									35 / 2,4	2520	1990	1930	1820	1765	1680
									38 / 2,6	2635	2080	2020	1905	1845	1755
									41 / 2,8	2755	2175	2110	1990	1925	1835
									44 / 3,0	2895	2285	2220	2095	2025	1930
									46 / 3,2	2990	2360	2290	2160	2090	1995
									49 / 3,4	3090	2440	2370	2235	2165	2060
									52 / 3,6	3190	2520	2445	2310	2230	2125
55 / 3,8	3275	2585	2510	2370	2290	2185									
58 / 4,0	3360	2655	2575	2430	2350	2240									
270/95 R38	TL	140 A8/ 140 B	W9	W8, W10	275	1479	4437	673	17 / 1,2	1780	1475	1420	1325	1325	-
									20 / 1,4	1980	1640	1580	1475	1475	-
									23 / 1,6	2145	1780	1715	1600	1600	-
									26 / 1,8	2280	1890	1820	1700	1700	-
									29 / 2,0	2380	1975	1900	1775	1775	-
									32 / 2,2	2450	2030	1955	1825	1825	-
									35 / 2,4	2515	2085	2010	1875	1875	-
									38 / 2,6	2650	2195	2115	1975	1975	-
									41 / 2,8	2750	2280	2195	2050	2050	-
									44 / 3,0	2850	2360	2275	2125	2125	-
									46 / 3,2	2985	2470	2385	2225	2225	-
									49 / 3,4	3085	2555	2465	2300	2300	-
									52 / 3,6	3185	2640	2545	2375	2375	-
55 / 3,8	3250	2695	2595	2425	2425	-									
58 / 4,0	3350	2775	2675	2500	2500	-									

Load capacity on recommended speed and pressure is stated with dark colour.

DESCRIPTION

- * For load capacity on various speed ratings, and inflation figures, please consult your sales representative.
- ** Load capacity on standard speed and weight

- Our company is entitled to make any change on any information in this catalogue, without further notice.
- This catalogue annuls all the previous catalogues
- All figures are for reference; our company is not responsible for printing errors.

Tractor Radial · Characteristics of TR-120

Tire Size	TT/TL	Load/Speed Index	Rims		Inflated Dimensions (No Load)		Inflated Dimensions (W/Load)		Inflation Pressure (psi/bar)	Load capacity per tire, kg					
			Recom (inch)	Permitted (inch)	Section Width (mm)	Outer Diameter (mm)	Dynamic Rolling Circumference (mm)	Static Loaded Radius (mm)		Speed, km/h					
										10	25	30	40	50	65
230/95 R40	TL	132 D/ 135 A8	W7	W8	228	1454	4362	684	17 / 1,2	1550	1280	1235	1155	1115	1060
									20 / 1,4	1720	1430	1375	1285	1240	1180
									23 / 1,6	1870	1550	1490	1395	1345	1280
									26 / 1,8	1970	1635	1570	1470	1415	1350
									29 / 2,0	2075	1720	1655	1550	1490	1420
									32 / 2,2	2130	1770	1700	1590	1530	1460
									35 / 2,4	2190	1815	1750	1635	1575	1500
									38 / 2,6	2290	1900	1830	1710	1650	1590
									41 / 2,8	2395	1985	1910	1790	1720	1680
									44 / 3,0	2520	2090	2015	1885	1815	1740
									46 / 3,2	2600	2150	2075	1940	1870	1780
									49 / 3,4	2690	2225	2140	2005	1930	1840
									52 / 3,6	2775	2300	2210	2070	1995	1900
55 / 3,8	2850	2360	2270	2125	2050	1950									
58 / 4,0	2920	2420	2330	2180	2100	2000									
210/95 R44	TL	120 A8/ 120 B	W7	W6	211	1522	4616	723	17 / 1,2	1315	1090	1050	980	980	-
									20 / 1,4	1465	1215	1170	1095	1095	-
									23 / 1,6	1615	1340	1290	1205	1205	-
									26 / 1,8	1690	1400	1350	1260	1260	-
									29 / 2,0	1765	1465	1410	1320	1320	-
									32 / 2,2	1820	1510	1455	1360	1360	-
									35 / 2,4	1880	1555	1500	1400	1400	-
230/95 R44	TL	132 A8/ 132 B	W7	W8	230	1568	4748	733	17 / 1,2	1505	1245	1200	1120	1120	-
									20 / 1,4	1665	1380	1330	1240	1240	-
									23 / 1,6	1825	1510	1460	1360	1360	-
									26 / 1,8	1905	1580	1520	1420	1420	-
									29 / 2,0	2010	1665	1605	1500	1500	-
									32 / 2,2	2065	1710	1650	1540	1540	-
									35 / 2,4	2120	1755	1695	1580	1580	-
									38 / 2,6	2255	1865	1800	1680	1680	-
									41 / 2,8	2335	1935	1865	1740	1740	-
									44 / 3,0	2440	2025	1950	1820	1820	-
									46 / 3,2	2520	2090	2015	1880	1880	-
									49 / 3,4	2600	2155	2080	1940	1940	-
52 / 3,6	2680	2220	2140	2000	2000	-									

Load capacity on recommended speed and pressure is stated with dark colour.

Tractor Radial · Characteristics of **TR-120**

Tire Size	TT/ TL	Load/ Speed Index	Rims		Inflated Dimensions (No Load)		Inflated Dimensions (W/Load)		Inflation Pressure (psi/bar)	Load capacity per tire, kg					
			Recom (inch)	Permitted (inch)	Section Width (mm)	Outer Diameter (mm)	Dynamic Rolling Circumference (mm)	Static Loaded Radius (mm)		Speed, km/h					
										10	25	30	40	50	65
270/95 R44	TL	142 A8/ 142 B	W9	W8, W10	275	1632	4896	770	17 / 1,2	1885	1560	1505	1405	1405	-
									20 / 1,4	2100	1740	1675	1565	1565	-
									23 / 1,6	2275	1885	1815	1700	1700	-
									26 / 1,8	2415	2005	1930	1805	1805	-
									29 / 2,0	2525	2090	2015	1885	1885	-
									32 / 2,2	2595	2150	2070	1935	1935	-
									35 / 2,4	2665	2210	2130	1990	1990	-
									38 / 2,6	2810	2325	2245	2095	2095	-
									41 / 2,8	2915	2415	2330	2175	2175	-
									44 / 3,0	3020	2505	2415	2255	2255	-
									46 / 3,2	3165	2620	2525	2360	2360	-
									49 / 3,4	3270	2710	2610	2440	2440	-
									52 / 3,6	3375	2795	2695	2520	2520	-
55 / 3,8	3445	2855	2755	2575	2575	-									
58 / 4,0	3555	2945	2840	2650	2650	-									
270/95 R46	TL	144 A8/ 141 D	W9	W8, W9, W10	275	1682	4990	795	17 / 1,2	1930	1700	1660	1565	1510	1440
									20 / 1,4	2140	1890	1835	1735	1675	1595
									23 / 1,6	2345	2075	2010	1900	1835	1750
									26 / 1,8	2465	2180	2115	2000	1930	1840
									29 / 2,0	2585	2285	2220	2100	2025	1930
									32 / 2,2	2655	2345	2280	2155	2075	1980
									35 / 2,4	2725	2410	2340	2210	2130	2030
									38 / 2,6	2860	2530	2455	2320	2240	2135
									41 / 2,8	3000	2650	2575	2435	2350	2240
									44 / 3,0	3120	2755	2675	2530	2445	2330
									46 / 3,2	3240	2865	2780	2630	2540	2420
									49 / 3,4	3345	2955	2870	2715	2620	2495
									52 / 3,6	3450	3050	2960	2800	2700	2575

Load capacity on recommended speed and pressure is stated with dark colour.

DESCRIPTION

- * For load capacity on various speed ratings, and inflation figures, please consult your sales representative.
- ** Load capacity on standard speed and weight

- Our company is entitled to make any change on any information in this catalogue, without further notice.
- This catalogue annuls all the previous catalogues
- All figures are for reference; our company is not responsible for printing errors.

Tractor Radial · Characteristics of **TR-120**

Tire Size	TT/TL	Load/Speed Index	Rims		Inflated Dimensions (No Load)		Inflated Dimensions (W/Load)		Inflation Pressure (psi/bar)	Load capacity per tire, kg					
			Recom (inch)	Permitted (inch)	Section Width (mm)	Outer Diameter (mm)	Dynamic Rolling Circumference (mm)	Static Loaded Radius (mm)		Speed, km/h					
										10	25	30	40	50	65
300/95 R46	TL	148 A8/ 148 B	W9	DW10, W10, DW11, W11	295	1738	5214	807	17 / 1,2	2240	1855	1790	1670	1670	-
									20 / 1,4	2495	2065	1990	1860	1860	-
									23 / 1,6	2705	2240	2160	2020	2020	-
									26 / 1,8	2875	2380	2295	2145	2145	-
									29 / 2,0	3000	2485	2395	2240	2240	-
									32 / 2,2	3085	2555	2465	2300	2300	-
									35 / 2,4	3170	2625	2530	2365	2365	-
									38 / 2,6	3335	2765	2665	2490	2490	-
									41 / 2,8	3465	2870	2765	2585	2585	-
									44 / 3,0	3590	2975	2865	2680	2680	-
									46 / 3,2	3760	3115	3000	2805	2805	-
									49 / 3,4	3885	3220	3105	2900	2900	-
									52 / 3,6	4010	3325	3205	2995	2995	-
									55 / 3,8	4095	3395	3270	3060	3060	-
58 / 4,0	4225	3500	3375	3150	3150	-									
230/95 R48	TL	136 A2/ 139 A8	W7	W8	228	1657	5031	796	17 / 1,2	1725	1430	1380	1290	1245	1185
									20 / 1,4	1905	1580	1520	1420	1375	1310
									23 / 1,6	2085	1730	1665	1555	1505	1435
									26 / 1,8	2200	1820	1755	1640	1590	1510
									29 / 2,0	2310	1915	1845	1725	1670	1590
									32 / 2,2	2375	1970	1895	1770	1715	1635
									35 / 2,4	2440	2025	1950	1820	1760	1680
									38 / 2,6	2555	2120	2040	1905	1840	1760
									41 / 2,8	2670	2215	2130	1990	1925	1835
									44 / 3,0	2815	2330	2245	2095	2030	1935
									46 / 3,2	2900	2400	2315	2160	2090	1995
									49 / 3,4	2995	2480	2390	2235	2160	2060
									52 / 3,6	3090	2565	2470	2310	2230	2130
									55 / 3,8	3170	2630	2535	2370	2290	2185
58 / 4,0	3255	2700	2600	2430	2350	2240									

Load capacity on recommended speed and pressure is stated with dark colour.

DESCRIPTION

* For load capacity on various speed ratings, and inflation figures, please consult your sales representative.

** Load capacity on standard speed and weight

- Our company is entitled to make any change on any information in this catalogue, without further notice.
- This catalogue annuls all the previous catalogues
- All figures are for reference; our company is not responsible for printing errors.

Tractor Radial · Characteristics of **TR-120**

Tire Size	TT/ TL	Load/ Speed Index	Rims		Inflated Dimensions (No Load)		Inflated Dimensions (W/Load)		Inflation Pressure (psi/bar)	Load capacity per tire, kg					
			Recom (inch)	Permitted (inch)	Section Width (mm)	Outer Diameter (mm)	Dynamic Rolling Circumference (mm)	Static Loaded Radius (mm)		Speed, km/h					
										10	25	30	40	50	65
270/95 R48	TL	144 A8/ 144 B	W9	W8 W10	275	1733	5198	816	17 / 1,2	1990	1650	1590	1485	1485	-
									20 / 1,4	2215	1835	1770	1655	1655	-
									23 / 1,6	2405	1990	1920	1795	1795	-
									26 / 1,8	2555	2115	2040	1905	1905	-
									29 / 2,0	2665	2210	2130	1990	1990	-
									32 / 2,2	2740	2270	2190	2045	2045	-
									35 / 2,4	2815	2335	2250	2100	2100	-
									38 / 2,6	2965	2460	2370	2215	2215	-
									41 / 2,8	3080	2550	2460	2300	2300	-
									44 / 3,0	3190	2645	2550	2380	2380	-
									46 / 3,2	3340	2770	2670	2495	2495	-
									49 / 3,4	3455	2860	2760	2580	2580	-
									52 / 3,6	3565	2955	2850	2660	2660	-
55 / 3,8	3640	3015	2910	2720	2720	-									
								58 / 4,0	3755	3110	3000	2800	2800	-	
300/95 R52	TL	156 D/ 159 A8	W9	DW10, W10 DW11, W11	295	1891	5673	896	17 / 1,2	2230	1850	1780	1665	1600	1520
									20 / 1,4	2580	2140	2060	1925	1850	1760
									23 / 1,6	2875	2380	2295	2145	2060	1960
									26 / 1,8	3110	2575	2485	2320	2230	2120
									29 / 2,0	3285	2720	2625	2450	2355	2240
									32 / 2,2	3405	2820	2720	2540	2440	2320
									35 / 2,4	3520	2915	2810	2625	2520	2400
									38 / 2,6	3755	3110	3000	2800	2690	2560
									41 / 2,8	3930	3255	3140	2935	2815	2680
									44 / 3,0	4105	3400	3280	3065	2940	2800
									46 / 3,2	4340	3595	3465	3240	3110	2960
									49 / 3,4	4515	3740	3605	3370	3235	3080
									52 / 3,6	4690	3885	3745	3500	3360	3200
									55 / 3,8	4810	3985	3840	3590	3445	3280
									58 / 4,0	4985	4130	3980	3720	3570	3400
64 / 4,4	5455	4520	4355	4070	3910	3720									
								70 / 4,8	5865	4860	4685	4375	4200	4000	

Load capacity on recommended speed and pressure is stated with dark colour.

DESCRIPTION

- * For load capacity on various speed ratings, and inflation figures, please consult your sales representative.
- ** Load capacity on standard speed and weight

- Our company is entitled to make any change on any information in this catalogue, without further notice.
- This catalogue annuls all the previous catalogues
- All figures are for reference; our company is not responsible for printing errors.

Tractor Radial · Characteristics of **TR-120**

Tire Size	TT/TL	Load/Speed Index	Rims		Inflated Dimensions (No Load)		Inflated Dimensions (W/Load)		Inflation Pressure (psi/bar)	Load capacity per tire, kg					
			Recom (inch)	Permitted (inch)	Section Width (mm)	Outer Diameter (mm)	Dynamic Rolling Circumference (mm)	Static Loaded Radius (mm)		Speed, km/h					
										10	25	30	40	50	65
270/95 R54	TL	146 D/ 149 A8	W9	W8, W10	275	1886	5658	892	17 / 1,2	2130	1885	1830	1720	1670	1590
									20 / 1,4	2370	2100	2035	1915	1860	1770
									23 / 1,6	2570	2275	2210	2080	2015	1920
									26 / 1,8	2710	2400	2330	2195	2125	2025
									29 / 2,0	2855	2520	2450	2310	2235	2130
									32 / 2,2	2935	2595	2520	2375	2300	2190
									35 / 2,4	3015	2670	2590	2440	2360	2250
									38 / 2,6	3160	2790	2710	2550	2470	2355
									41 / 2,8	3300	2915	2830	2665	2580	2460
									44 / 3,0	3440	3040	2950	2780	2690	2565
									46 / 3,2	3580	3160	3070	2890	2800	2670
									49 / 3,4	3700	3270	3175	2990	2895	2760
									52 / 3,6	3820	3380	3280	3090	2990	2850
									55 / 3,8	3920	3465	3365	3170	3070	2925
58 / 4,0	4020	3555	3450	3250	3150	3000									
VF320/90 R46	TL	165 D	W11	W10, DW10 W11, DW11	323	1744	5230	814	17 / 1,2	3310	2930	2840	2700	2590	2470
									20 / 1,4	3690	3265	3165	3015	2885	2755
									23 / 1,6	4070	3600	3490	3330	3185	3040
									26 / 1,8	4280	3780	3665	3500	3345	3190
									29 / 2,0	4485	3965	3845	3665	3510	3345
									32 / 2,2	4620	4085	3965	3780	3615	3445
									35 / 2,4	4760	4210	4085	3890	3725	3550
									38 / 2,6	5000	4420	4290	4085	3910	3730
									41 / 2,8	5240	4635	4500	4285	4100	3910
									44 / 3,0	5450	4815	4675	4455	4265	4065
									46 / 3,2	5660	5000	4855	4625	4430	4220
									49 / 3,4	5830	5155	5000	4765	4565	4350
									52 / 3,6	6000	5310	5150	4905	4700	4480
									55 / 3,8	6175	5460	5295	5045	4830	4610
									58 / 4,0	6350	5610	5445	5190	4965	4740
61 / 4,2	6625	5855	5680	5415	5180	4945									
64 / 4,4	6900	6100	5920	5640	5400	5150									

Load capacity on recommended speed and pressure is stated with dark colour.

DESCRIPTION

- * For load capacity on various speed ratings, and inflation figures, please consult your sales representative.
- ** Load capacity on standard speed and weight

- Our company is entitled to make any change on any information in this catalogue, without further notice.
- This catalogue annuls all the previous catalogues
- All figures are for reference; our company is not responsible for printing errors.

Tractor Radial · Characteristics of **TR-120**

Tire Size	TT/ TL	Load/ Speed Index	Rims		Inflated Dimensions (No Load)		Inflated Dimensions (W/Load)		Inflation Pressure (psi/bar)	Load capacity per tire, kg					
			Recom (inch)	Permitted (inch)	Section Width (mm)	Outer Diameter (mm)	Dynamic Rolling Circumference (mm)	Static Loaded Radius (mm)		Speed, km/h					
										10	25	30	40	50	65
380/90 R46	TL	159 D/ 162 A8	W12	W11, W13	380	1852	5556	877	17 / 1,2	3375	2795	2695	2520	2435	2320
									20 / 1,4	3760	3115	3000	2805	2715	2585
									23 / 1,6	4075	3375	3255	3040	2940	2800
									26 / 1,8	4330	3590	3460	3230	3125	2975
									29 / 2,0	4520	3745	3610	3375	3265	3110
									32 / 2,2	4650	3850	3715	3470	3355	3195
									35 / 2,4	4775	3955	3815	3565	3450	3285
									38 / 2,6	5030	4170	4020	3755	3630	3460
									41 / 2,8	5220	4325	4170	3895	3770	3590
									44 / 3,0	5415	4485	4325	4040	3905	3720
									46 / 3,2	5665	4695	4525	4230	4090	3895
									49 / 3,4	5860	4855	4680	4370	4230	4025
									52 / 3,6	6050	5010	4830	4515	4365	4160
55 / 3,8	6175	5115	4935	4610	4460	4245									
								58 / 4,0	6365	5275	5085	4750	4595	4375	
VF380/90 R46	TL	173 D	W13	W12, DW12, W13, DW13	383	1852	5556	870	17 / 1,2	3430	3210	3180	3120	3120	3120
									20 / 1,4	3825	3580	3545	3475	3475	3475
									23 / 1,6	4220	3950	3910	3835	3835	3835
									26 / 1,8	4435	4150	4110	4000	4000	4000
									29 / 2,0	4650	4350	4310	4160	4160	4160
									32 / 2,2	4790	4485	4440	4320	4320	4320
									35 / 2,4	4930	4620	4575	4485	4485	4485
									38 / 2,6	5180	4855	4810	4710	4710	4710
									41 / 2,8	5435	5090	5040	4940	4940	4940
									44 / 3,0	5650	5290	5235	5135	5135	5135
									46 / 3,2	5860	5490	5435	5330	5330	5330
									49 / 3,4	6040	5660	5600	5490	5490	5490
									52 / 3,6	6220	5825	5770	5655	5655	5655
									55 / 3,8	6400	5990	5935	5820	5820	5820
									58 / 4,0	6580	6160	6100	5980	5980	5980
61 / 4,2	6865	6430	6365	6240	6240	6240									
								64 / 4,4	7150	6695	6630	6500	6500	6500	

Load capacity on recommended speed and pressure is stated with dark colour.

DESCRIPTION

- * For load capacity on various speed ratings, and inflation figures, please consult your sales representative.
- ** Load capacity on standard speed and weight

- Our company is entitled to make any change on any information in this catalogue, without further notice.
- This catalogue annuls all the previous catalogues
- All figures are for reference; our company is not responsible for printing errors.

Tractor Radial · Characteristics of **TR-120**

Tire Size	TT/TL	Load/Speed Index	Rims		Inflated Dimensions (No Load)		Inflated Dimensions (W/Load)		Inflation Pressure (psi/bar)	Load capacity per tire, kg					
			Recom (inch)	Permitted (inch)	Section Width (mm)	Outer Diameter (mm)	Dynamic Rolling Circumference (mm)	Static Loaded Radius (mm)		Speed, km/h					
										10	25	30	40	50	65
340/85 R46	TL	153 A8/ 150 D	W12	W11	343	1746	5262	824	17 / 1,2	2720	2220	2150	2045	1970	1880
									20 / 1,4	3010	2460	2390	2265	2180	2080
									23 / 1,6	3300	2670	2620	2485	2395	2280
									26 / 1,8	3470	2820	2755	2610	2520	2395
									29 / 2,0	3645	2975	2890	2740	2640	2510
									32 / 2,2	3740	3075	2965	2810	2710	2580
									35 / 2,4	3840	3135	3040	2885	2780	2646
									38 / 2,6	4035	3290	3195	3030	2920	2780
									41 / 2,8	4230	3450	3350	3175	3060	2915
									44 / 3,0	4435	3620	3510	3330	3210	3055
									46 / 3,2	4570	3730	3620	3430	3310	3150
									49 / 3,4	4715	3850	3735	3540	3415	3250
52 / 3,6	4860	3970	3850	3650	3520	3350									
340/85 R48	TL	151 D/ 154 A8	W12	W11	343	1797	5391	844	17 / 1,2	2815	2335	2250	2100	2030	1935
									20 / 1,4	3120	2585	2490	2325	2250	2140
									23 / 1,6	3420	2835	2730	2550	2465	2350
									26 / 1,8	3570	2960	2850	2665	2575	2450
									29 / 2,0	3770	3125	3010	2815	2720	2590
									32 / 2,2	3870	3210	3090	2890	2790	2660
									35 / 2,4	3970	3290	3170	2965	2865	2730
									38 / 2,6	4225	3500	3375	3150	3045	2900
									41 / 2,8	4375	3625	3495	3265	3155	3005
									44 / 3,0	4575	3790	3655	3415	3300	3140
									46 / 3,2	4725	3915	3775	3525	3410	3245
									49 / 3,4	4875	4040	3895	3640	3625	3450
52 / 3,6	5025	4165	4015	3750	3625	3450									

Load capacity on recommended speed and pressure is stated with dark colour.

VF: VERY HIGH FLEXION

DESCRIPTION

* For load capacity on various speed ratings, and inflation figures, please consult your sales representative.

** Load capacity on standard speed and weight

- Our company is entitled to make any change on any information in this catalogue, without further notice.
- This catalogue annuls all the previous catalogues
- All figures are for reference; our company is not responsible for printing errors.





TR-130 /65

Tractor Radial

PERFORMANCE INFORMATION

R-1W tire for high power tractors.



FEATURES

Long service life / Durability

Strong carcass and high-quality tread compound ensure longer service life and enable maximum performance under heavy loads.

Provides driving comfort both on the road and the field.

High traction / Self-cleaning

Special tread geometry reduces slippage by improving traction which in turn, leads to significant fuel savings.

Designed to transfer torque power to the ground effectively on any terrain.

Low soil compaction / Reduced slip

Wider footprint and optimized lug angle contributes to crop productivity by minimizing soil compaction.

Elastic structure absorbs impacts and demonstrates better flotation.

SIZES 600/65 R28 · 600/65 R42

Tractor Radial · Characteristics of **TR-130/65**

Tire Size	TT/TL	Load/Speed Index	Rims		Inflated Dimensions (No Load)		Inflated Dimensions (W/Load)		Inflation Pressure (psi/bar)	Load capacity per tire, kg												
			Recom (inch)	Permitted (inch)	Section Width (mm)	Outer Diameter (mm)	Dynamic Rolling Circumference (mm)	Static Loaded Radius (mm)		Speed, km/h												
										10	30	40	50	65								
600/65 R28	TL	154D/157A8	DW20B	W18L	591	1491	4473	683	9/0.6	2470	2030	1940	1855	1765								
									12/0.8	2890	2375	2270	2170	2065								
									15/1.0	3310	2720	2600	2485	2365								
									17/1.2	3675	3020	2890	2760	2625								
									20/1.4	4045	3325	3180	3035	2890								
									23/1.6	4360	3580	3425	3270	3115								
									26/1.8	4620	3795	3630	3465	3300								
									28/1.9	4725	3885	3715	3545	3375								
									29/2.0	4885	4015	3840	3665	3490								
									32/2.2	5040	4140	3960	3780	3600								
								35/2.4	5250	4315	4125	3940	3750									
600/65 R42	TL	154D/157A8	DW20B	W18L	591	1847	5541	683	9/0.6	2940	2415	2310	2205	2100								
									12/0.8	3465	2850	2725	2600	2475								
									15/1.0	3940	3235	3095	2955	2815								
									16/1.1	4175	3430	3280	3135	2985								
									17/1.2	4410	3625	3465	3310	3150								
									19/1.3	4620	3795	3630	3465	3300								
									20/1.4	4830	3970	3795	3625	3450								
									22/1.5	5040	4140	3960	3780	3600								
																	23/1.6	5250	4315	4125	3940	3750

Load capacity on recommended speed and pressure is stated with dark colour.

DESCRIPTION

- * For load capacity on various speed ratings, and inflation figures, please consult your sales representative.
- ** Load capacity on standard speed and weight

- Our company is entitled to make any change on any information in this catalogue, without further notice.
- This catalogue annuls all the previous catalogues
- All figures are for reference; our company is not responsible for printing errors.



TR-130 /70

Tractor Radial

PERFORMANCE INFORMATION

R-1W tire for high power tractors.



FEATURES

Long service life / Durability

Strong carcass and high-quality tread compound ensure longer service life and enable maximum performance under heavy loads.

Provides driving comfort both on the road and the field.

High traction / Self-cleaning

Special tread geometry reduces slippage by improving traction which in turn, leads to significant fuel savings.

Designed to transfer torque power to the ground effectively on any terrain.

Low soil compaction / Reduced slip

Wider footprint and optimized lug angle contributes to crop productivity by minimizing soil compaction.

Elastic structure absorbs impacts and demonstrates better flotation.

SIZES

600/70 R28 · 600/70 R30 · 600/70 R34 · 800/70 R38 · 620/70 R42

Tractor Radial · Characteristics of **TR-130/70**

Tire Size	TT/TL	Load/Speed Index	Rims		Inflated Dimensions (No Load)		Inflated Dimensions (W/Load)		Inflation Pressure (psi/bar)	Load capacity per tire, kg				
			Recom (inch)	Permitted (inch)	Section Width (mm)	Outer Diameter (mm)	Dynamic Rolling Circumference (mm)	Static Loaded Radius (mm)		Speed, km/h				
										10	30	40	50	65
600/70 R28	TL	161 D	DW20B	DW18L, W18L	591	1551	4653	692	9/0,6	2785	2285	2180	2090	1990
									12/0,8	3240	2660	2530	2430	2315
									15/1,0	3690	3030	2885	2770	2635
									17/1,2	4145	3405	3240	3110	2960
									20/1,4	4595	3775	3600	3450	3285
									23/1,6	5050	4150	3950	3790	3640
									26/1,8	5310	4360	4150	3980	3795
									29/2,0	5570	4575	4355	4175	3980
									32/2,2	5730	4705	4480	4300	4090
									35/2,4	5890	4840	4610	4420	4210
									38/2,6	6150	5050	4810	4610	4395
41/2,8	6475	5320	5065	4855	4625									
600/70 R30	TL	158 D	DW20B	DW18L, W18L	591	1602	4806	717	9/0,6	2800	2300	2190	2100	2000
									12/0,8	3215	2640	2515	2410	2295
									15/1,0	3690	3035	2890	2770	2635
									17/1,2	4165	3425	3260	3125	2975
									20/1,4	4645	3815	3630	3485	3315
									23/1,6	5120	4205	4005	3840	3655
									26/1,8	5355	4400	4190	4020	3825
									28/1,9	5475	4500	4285	4110	3910
									29/2,0	5595	4595	4375	4195	3995
									32/2,2	5775	4745	4515	4330	4125
									35/2,4	5950	4890	4655	4465	4250

Load capacity on recommended speed and pressure is stated with dark colour.

DESCRIPTION

- * For load capacity on various speed ratings, and inflation figures, please consult your sales representative.
- ** Load capacity on standard speed and weight

- Our company is entitled to make any change on any information in this catalogue, without further notice.
- This catalogue annuls all the previous catalogues
- All figures are for reference; our company is not responsible for printing errors.

Tractor Radial · Characteristics of **TR-130/70**

Tire Size	TT/TL	Load/Speed Index	Rims		Inflated Dimensions (No Load)		Inflated Dimensions (W/Load)		Inflation Pressure (psi/bar)	Load capacity per tire, kg				
			Recom (inch)	Permitted (inch)	Section Width (mm)	Outer Diameter (mm)	Dynamic Rolling Circumference (mm)	Static Loaded Radius (mm)		Speed, km/h				
										10	30	40	50	65
600/70 R34	TL	160 D	DW18L	DW20B, W18L	591	1723	5169	776	9/0,6	2965	2435	2320	2225	2115
									12/0,8	3405	2795	2665	2555	2430
									15/1,0	3910	3210	3060	2930	2790
									17/1,2	4410	3625	3450	3310	3150
									20/1,4	4915	4040	3845	3690	3510
									23/1,6	5420	4455	4240	4065	3870
									26/1,8	5670	4660	4435	4255	4050
									28/1,9	5800	4765	4535	4350	4140
									29/2,0	5925	4865	4635	4445	4230
									32/2,2	6115	5020	4780	4585	4365
								35/2,4	6300	5175	4930	4725	4500	
800/70 R38	TL	178 D/181A8	DW25B	DW27B	795	2055	6165	905	9/0,6	4935	4055	3880	3705	3525
									12/0,8	5670	4660	4455	4255	4050
									15/1,0	6510	5350	5115	4885	4650
									17/1,2	7350	6040	5775	5515	5250
									20/1,4	8190	6730	6435	6145	5850
									23/1,6	9030	7420	7095	6775	6450
									26/1,8	9450	7765	7425	7090	6750
									28/1,9	9660	7935	7590	7245	6900
									29/2,0	9870	8110	7755	7405	7050
									32/2,2	10185	8370	8005	7640	7275
								35/2,4	10500	8625	8250	7875	7500	
620/70 R42	TL	166 D	DW20B	-	625	1971	5913	891	9/0,6	3490	2865	2730	2620	2495
									12/0,8	4010	3295	3135	3010	2865
									15/1,0	4605	3780	3600	3455	3290
									17/1,2	5195	4270	4065	3900	3710
									20/1,4	5790	4755	4530	4345	4135
									23/1,6	6385	5245	4995	4790	4560
									26/1,8	6680	5490	5225	5010	4770
									28/1,9	6830	5610	5340	5120	4880
									29/2,0	6975	5730	5460	5235	4985
									32/2,2	7200	5915	5630	5400	5145
								35/2,4	7420	6095	5805	5565	5300	

Load capacity on recommended speed and pressure is stated with dark colour.

DESCRIPTION

* For load capacity on various speed ratings, and inflation figures, please consult your sales representative.

** Load capacity on standard speed and weight

- Our company is entitled to make any change on any information in this catalogue, without further notice.
- This catalogue annuls all the previous catalogues
- All figures are for reference; our company is not responsible for printing errors.





TR-130 /PLUS

Tractor Radial

PERFORMANCE INFORMATION

R-1W tire for high power tractors.



FEATURES

Improved Flexion

Designed to transfer torque power to the ground effectively on any terrain. Special tread geometry reduces slippage by improving traction which in turn, leads to significant fuel savings.

Wider footprint and optimized lug angle contributes to crop productivity by minimizing soil

compaction.

Elastic structure absorbs impacts and demonstrates better flotation.

Strong carcass and high-quality tread compound ensure longer service life and enable maximum performance under heavy loads.

SIZES 710/70 R38 • 710/70 R42 • VF710/70 R42 • 650/65 R42 • VF650/65 R42 • IF710/65 R46

Tractor Radial · Characteristics of **TR-130/PLUS**

Tire Size	TT/TL	Load/Speed Index	Rims		Inflated Dimensions (No Load)		Inflated Dimensions (W/Load)		Inflation Pressure (psi/bar)	Load capacity per tire, kg				
			Recom (inch)	Permitted (inch)	Section Width (mm)	Outer Diameter (mm)	Dynamic Rolling Circumference (mm)	Static Loaded Radius (mm)		Speed, km/h				
										10	30	40	50	65
710/70 R38	TL	171 D/174A8	DW23B	-	716	1959	5877	941	9/0,6	4050	3325	3150	3040	2895
									12/0,8	4650	3820	3620	3490	3325
									15/1,0	5340	4385	4155	4005	3815
									17/1,2	6030	4955	4690	4525	4305
									20/1,4	6720	5520	5230	5040	4800
									23/1,6	7405	6085	5765	5555	5290
									26/1,8	7750	6370	6030	5815	5535
									28/1,9	7925	6510	6165	5945	5660
									29/2,0	8095	6650	6300	6075	5785
									32/2,2	8355	6865	6500	6265	5970
35/2,4	8610	7075	6700	6460	6150									
710/70 R42	TL	173 D/176A8	DW23B	-	716	2061	6183	891	9/0,6	4280	3515	3340	3210	3055
									12/0,8	4915	4040	3835	3690	3510
									15/1,0	5645	4635	4405	4235	4030
									17/1,2	6370	5235	4970	4780	4550
									20/1,4	7100	5835	5540	5325	5070
									23/1,6	7830	6430	6110	5870	5590
									26/1,8	8190	6730	6390	6145	5850
									28/1,9	8375	6880	6535	6280	5980
									29/2,0	8555	7030	6675	6420	6110
									32/2,2	8830	7255	6890	6625	6305
35/2,4	9100	7475	7100	6825	6500									
VF710/70 R42	TL	185 D	DW25B	DW23, DW24	705	2061	5990	900	9/0,6	5820	5000	4760	4560	4345
									12/0,8	6690	5745	5470	5240	4995
									15/1,0	7680	6595	6280	6020	5735
									17/1,2	8670	7450	7090	6800	6475
									20/1,4	9660	8300	7900	7570	7215
									23/1,6	10655	9150	8710	8350	7955
									26/1,8	11148	9575	9115	8740	8320
									29/2,0	11640	10000	9520	9130	8690
									32/2,2	12015	10320	9825	9420	8970
									35/2,4	12390	10640	10130	9710	9250

Load capacity on recommended speed and pressure is stated with dark colour.

DESCRIPTION

- * For load capacity on various speed ratings, and inflation figures, please consult your sales representative.
- ** Load capacity on standard speed and weight

- Our company is entitled to make any change on any information in this catalogue, without further notice.
- This catalogue annuls all the previous catalogues
- All figures are for reference; our company is not responsible for printing errors.

Tractor Radial · Characteristics of **TR-130/PLUS**

Tire Size	TT/TL	Load/Speed Index	Rims		Inflated Dimensions (No Load)		Inflated Dimensions (W/Load)		Inflation Pressure (psi/bar)	Load capacity per tire, kg				
			Recom (inch)	Permitted (inch)	Section Width (mm)	Outer Diameter (mm)	Dynamic Rolling Circumference (mm)	Static Loaded Radius (mm)		Speed, km/h				
										10	30	40	50	65
650/65 R42	TL	170 D/173 A8	DW20B	-	645	1913	5739	853,2	9/0,6	3360	2760	2600	2520	2400
									12/0,8	3865	3175	2990	2900	2760
									15/1,0	4455	3660	3445	3340	3180
									17/1,2	5040	4140	3900	3780	3600
									20/1,4	5460	4485	4225	4095	3900
									23/1,6	5965	4900	4615	4475	4260
									26/1,8	6300	5175	4875	4725	4500
									28/1,9	6470	5315	5005	4855	4620
									29/2,0	6640	5455	5135	4980	4740
									32/2,2	6890	5660	5330	5170	4920
									35/2,4	7140	5865	5525	5355	5100
									38/2,6	7480	6145	5785	5610	5340
									41/2,8	7815	6420	6045	5860	5580
44/3,0	8065	6625	6240	6050	5760									
								46/3,2	8400	6900	6500	6300	6000	
VF650/65 R42	TL	174 D	DW23B	DW21B	650	1913	5548	843	9/0,6	4490	3850	3670	3520	3350
									12/0,8	5210	4470	4250	4080	3890
									15/1,0	5930	5085	4840	4640	4420
									17/1,2	6735	5780	5500	5275	5025
									20/1,4	7450	6395	6090	5840	5560
									23/1,6	8170	7010	6675	6400	6100
									26/1,8	8510	7300	6955	6670	6355
									28/1,9	8740	7500	7140	6845	6525
IF710/65 R46	TL	183 D	DW25B	-	708	2092	6276	970	9/0,6	4570	3920	3735	3580	3410
									12/0,8	5390	4630	4405	4225	4025
									15/1,0	6210	5330	5075	4865	4635
									17/1,2	6920	5935	5650	5420	5160
									20/1,4	7735	6640	6320	6060	5775
									23/1,6	8440	7240	6895	6610	6300
									26/1,8	8850	7590	7230	6930	6605
									29/2,0	9260	7945	7565	7255	6910
									32/2,2	9610	8245	7850	7530	7170
									35/2,4	9965	8550	8140	7810	7435
									38/2,6	10430	8950	8525	8175	7785
									41/2,8	10900	9355	8910	8540	8135
									44/3,0	11395	9780	9310	8925	8500
								46/3,2	11725	10060	9580	9185	8750	

Load capacity on recommended speed and pressure is stated with dark colour.

VF: VERY HIGH FLEXION





TR-130 IF SERIES

PERFORMANCE INFORMATION

R-1W tire for high power tractors.



FEATURES

Long service life / Durability

Strong carcass and special tread compound ensure longer service life. Elastic structure effectively protects the tire by absorbing impacts.

Demonstrates superior performance under heavy loads with lower pressure compared to traditional radial tires.

Lower inflation pressure and sidewall flexibility improves driving comfort.

High traction / Self-cleaning

Special tread design provides exceptional traction.

Low soil compaction

Highly flexible sidewalls and large footprint offer lower soil compaction.

SIZES IF600/70 R30 • IF800/70 R38

Tractor Radial · Characteristics of **TR-130 IF SERIES**

Tire Size	TT/TL	Load/Speed Index	Rims		Inflated Dimensions (No Load)		Inflated Dimensions (W/Load)		Inflation Pressure (psi/bar)	Load capacity per tire, kg				
			Recom (inch)	Permitted (inch)	Section Width (mm)	Outer Diameter (mm)	Dynamic Rolling Circumference (mm)	Static Loaded Radius (mm)		Speed, km/h				
										10	30	40	50	65
IF600/70 R30	TL	165 D	21.00	20.00	625	1585	4690	702	12/0.8	2785	2785	2785	2785	2785
									14/1.0	3195	3195	3195	3195	3195
									17/1.2	3605	3605	3605	3605	3605
									21/1.4	4020	4020	4020	4020	4020
									23/1.6	4430	4430	4430	4430	4430
									29/2.0	4790	4790	4790	4790	4790
									35/2.4	5150	5150	5150	5150	5150
IF800/70 R38	TL	184 D	27.00	25.00	815	2085	6150	924	12/0.8	4860	4860	4860	4860	4860
									14/1.0	5580	5580	5580	5580	5580
									17/1.2	6300	6300	6300	6300	6300
									21/1.4	7020	7020	7020	7020	7020
									23/1.6	7740	7740	7740	7740	7740
									27/1.8	8000	8000	8000	8000	8000
									29/2.0	8460	8460	8460	8460	8460
									31/2.2	8750	8750	8750	8750	8750
									35/2.4	9000	9000	9000	9000	9000

Load capacity on recommended speed and pressure is stated with dark colour.

IF: Improved Flexion

DESCRIPTION

- * For load capacity on various speed ratings, and inflation figures, please consult your sales representative.
- ** Load capacity on standard speed and weight

- Our company is entitled to make any change on any information in this catalogue, without further notice.
- This catalogue annuls all the previous catalogues
- All figures are for reference; our company is not responsible for printing errors.



S-IRG 80

PERFORMANCE INFORMATION

Designed to be used in center pivot and linear irrigation systems.



FEATURES

Traction/Soil compaction

With its angle-optimised tread pattern, it provides excellent traction.

Its special tread pattern and width provide low soil compaction, which increases efficiency by protecting crops.

Self-cleaning

It offers fast self-cleaning feature with wide tooth intervals.

SIZES 14.9/13-24 · 11.2/10-38

Tractor Radial · Characteristics of **TR-130 IF SERIES**

Tire Size	TT/TL	Load/Speed Index	Rims		Inflated Dimensions (No Load)		Inflated Dimensions (W/Load)		Inflation Pressure (psi/bar)	Load capacity per tire, kg					
			Recom (inch)	Permitted (inch)	Section Width (mm)	Outer Diameter (mm)	Dynamic Rolling Circumference (mm)	Static Loaded Radius (mm)		Speed, km/h					
										10	15	20	25	30	40
14.9/13-24	TT	128/A6	W13	W11, W12	380	1250	3725	557	22/1,5	2280	2120	1955	1740	1630	1465
									23/1,6	2395	2225	2050	1830	1710	1540
									26/1,8	2520	2340	2160	1925	1800	1620
	TL								22/1,5	2280	2120	1955	1740	1630	1465
									23/1,6	2395	2225	2050	1830	1710	1540
									26/1,8	2520	2340	2160	1925	1800	1620
11.2/10-38	TT	117/A6	W10	-	272	1445	4321	398	22/1,5	1475	1370	1265	1130	1055	950
									24/1,6	1640	1520	1405	1250	1170	1055
									26/1,8	1800	1670	1540	1375	1285	1155

Load capacity on recommended speed and pressure is stated with dark colour.

DESCRIPTION

- * For load capacity on various speed ratings, and inflation figures, please consult your sales representative.
- ** Load capacity on standard speed and weight
- Our company is entitled to make any change on any information in this catalogue, without further notice.
- This catalogue annuls all the previous catalogues
- All figures are for reference; our company is not responsible for printing errors.

Trailer /
Implement

	VF HST-70	RM-80	
TR-60		RM-50	RM-60

TR-60

VFHST-70

RM-50

RM-80

RM-60

RM-70

SM-270

SM-160

IMP-80

IMP-40

IMP-90

IMP-100

IMP-110

IMP-70

IMP-60

SR-3

SM-350

RM-70

SM-160

IMP-40

IMP-100

IMP-70

SR-3

SM-270

IMP-80

IMP-90

IMP-110

IMP-60

SM-350



starmax Agricultural Tires Data Book

TR-60 TRAILER

PERFORMANCE INFORMATION

General purpose trailer tire.



FEATURES

Long service life / Durability

Offers long service life thanks to its wear-resistant tread compound.

The wide and long lugs provide comfortable drive while improving grip performance.

Tread profile enable high resistance to tread base fatigue.

Wide and strong body provides ultimate grip and high traction.

Special tread geometry provides efficient self-cleaning feature.

SIZE 10.0/75-15.3 · 11.5/80-15.3

Tractor Trailer · Characteristics of **TR-60 TRAILER**

Tire Size	PR	TT/TL	Load/Speed Index	Rims		Inflated Dimensions (No Load)		Inflated Dimensions (W/Load)		Inflation Pressure (psi/bar)	Load capacity per tire, kg					
				Recom (inch)	Permitted (inch)	Section Width (mm)	Outer Diameter (mm)	Dynamic Rolling Circumference (mm)	Static Loaded Radius (mm)		Speed, km/h					
											10	15	20	25	30	40
10.0/75-15.3	12	TT	114 / A6	9.00	-	264	760	2265	360	58 / 4,0	1615	1535	1450	1235	1075	860
										64 / 4,4	1680	1605	1515	1300	1120	895
										68 / 4,7	1770	1685	1595	1355	1180	945
11.5/80-15.3	12	TT	123 / A6	9.00	-	290	845	2518	391	51 / 3,5	2115	2015	1905	1625	1410	1130
										54 / 3,7	2215	2110	1990	1695	1475	1180
										59 / 4,1	2325	2215	2095	1785	1550	1240
		51 / 3,5								2115	2015	1905	1625	1410	1130	
		54 / 3,7								2215	2110	1990	1695	1475	1180	
		59 / 4,1								2325	2215	2095	1785	1550	1240	

Load capacity on recommended speed and pressure is stated with dark colour.

DESCRIPTION

- * For load capacity on various speed ratings, and inflation figures, please consult your sales representative.
- ** Load capacity on standard speed and weight

- Our company is entitled to make any change on any information in this catalogue, without further notice.
- This catalogue annuls all the previous catalogues
- All figures are for reference; our company is not responsible for printing errors.

VFHST-70 Trailer Radial

■ PERFORMANCE INFORMATION

Multipurpose VF (Very High Flexion) all steel radial tire designed to hold up to heavier loads.



■ FEATURES

Long service life / Durability

Thanks to VF (Very High Flexion) technology, offers equal loading and driving performance under low pressure levels, compared to conventional tires.

Tread compound provides resistance to cuts and wears on asphalt, hard soil and concrete roads.

Heavy load capacity / High performance

Special carcass structure offers high endurance against stubble impacts and fissures.

Wide footprint provides lower soil compaction.

Protects crops effectively with the help of its high flexion feature.

■ **SIZE** VF285/70 R19.5

Tractor Radial · Characteristics of VFHST-70

Tire Size	PR	TT/TL	Load/Speed Index	Rims		Inflated Dimensions (No Load)		Inflated Dimensions (W/Load)		Inflation Pressure (psi)	Load capacity per tire, kg
				Recom (inch)	Permitted (inch)	Section Width (mm)	Outer Diameter (mm)	Dynamic Rolling Circumference (mm)	Static Loaded Radius (mm)		Speed, km/h
											65
VF285/70 R19.5	TL	152 D	HLT-45	8,25	9.00	285	894	2530	402,2	35 / 2.41	2000
										38 / 2.62	2100
										41 / 2.82	2200
										44 / 3.03	2320
										46 / 3.17	2380
										49 / 3.37	2500
										52 / 3.58	2630
										55 / 3.79	2700
										58 / 4.00	2850
										61 / 4.20	3000
										64 / 4.41	3100
										67 / 4.62	3200
										70 / 4.82	3275
										73 / 5.03	3450
75 / 5.17	3550										
123 / 8.48	3550										

Load capacity on recommended speed and pressure is stated with dark colour.

VF: VERY HIGH FLEXION

DESCRIPTION

- * For load capacity on various speed ratings, and inflation figures, please consult your sales representative.
- ** Load capacity on standard speed and weight

- Our company is entitled to make any change on any information in this catalogue, without further notice.
- This catalogue annuls all the previous catalogues
- All figures are for reference; our company is not responsible for printing errors.





RM-50 Trailer

PERFORMANCE INFORMATION

Traction type trailer tire with high resistance.



FEATURES

Long life

Wide and deeper tread design provides high resistance against cuts and tread fatigue.

Heavy load capacity / Self-cleaning

Special tread and carcass structure offers high load capacity.

SIZES 9.00-16 • 11.5/80-15.3

Trailer · Characteristics of **RM-50**

Tire Size	PR	TT/TL	Load/Speed Index	Rims		Inflated Dimensions (No Load)		Inflated Dimensions (W/Load)		Inflation Pressure (psi/bar)	Load capacity per tire, kg				
				Recom (inch)	Permitted (inch)	Section Width (mm)	Outer Diameter (mm)	Dynamic Rolling Circumference (mm)	Static Loaded Radius (mm)		Speed, km/h				
											10	20	25	30	40
9.00-16	12	TT	125/A6	6.00F	5.50F, 6LB	247	881	2675	394	57 / 3.9	2020	1785	1675	1565	1410
										61 / 4.2	2115	1865	1750	1640	1475
	67 / 4.6	2320	2050							1925	1800	1620			
	67 / 4.6	2160	1910							1795	1675	1510			
	72 / 5.0	2365	2090							1960	1833	1650			
	80 / 5.5	2515	2225							2085	1950	1755			
	67 / 4.6	2160	1910							1795	1675	1510			
	72 / 5.0	2365	2090							1960	1833	1650			
									80 / 5.5	2515	2225	2085	1950	1755	
11.5/80-15.3	16	TL	141/A8	9.00	-	290	845	2600	382	75 / 5.2	3080	2770	2615	2465	2200
										81 / 5.6	3370	3040	2870	2700	2410
										90 / 6.2	3710	3340	3150	2970	2650

Load capacity on recommended speed and pressure is stated with dark colour.

DESCRIPTION

- * For load capacity on various speed ratings, and inflation figures, please consult your sales representative.
- ** Load capacity on standard speed and weight

- Our company is entitled to make any change on any information in this catalogue, without further notice.
- This catalogue annuls all the previous catalogues
- All figures are for reference; our company is not responsible for printing errors.





RM-80 Trailer

PERFORMANCE INFORMATION

Flexible and durable trailer tire.



FEATURES

Long life / Durability

Offers high resistance against cuts and stubble puncture thanks to its specially developed tread compound and geometry.

Heavy load capacity / Self-cleaning

Flexible carcass structure prevents sinking into the soil while protecting the tire by absorbing impacts.

Special tread and carcass structure offers high load capacity.

SIZE 9.00-16

Trailer · Characteristics of **RM-80**

Tire Size	PR	TT/TL	Load/Speed Index	Rims		Inflated Dimensions (No Load)		Inflated Dimensions (W/Load)		Inflation Pressure (psi/bar)	Load capacity per tire, kg				
				Recom (inch)	Permitted (inch)	Section Width (mm)	Outer Diameter (mm)	Dynamic Rolling Circumference (mm)	Static Loaded Radius (mm)		Speed, km/h				
											10	20	25	30	40
9.00-16	12	TT	125/A6	6.00F	5.50F, 6LB	247	881	2650	388	49 / 3.4	1895	1675	1570	1470	1320
										52 / 3.6	1940	1710	1605	1500	1350
										58 / 4.0	2130	1880	1765	1650	1485
	14	TT	128/A6							57 / 3.9	2020	1785	1675	1565	1410
										61 / 4.2	2115	1865	1750	1640	1475
										67 / 4.6	2320	2050	1925	1800	1620
	16	TT	131/A6							67 / 4.6	2160	1910	1795	1675	1510
										72 / 5.0	2365	2090	1960	1833	1650
										80 / 5.5	2515	2225	2085	1950	1755

Load capacity on recommended speed and pressure is stated with dark colour.

DESCRIPTION

- * For load capacity on various speed ratings, and inflation figures, please consult your sales representative.
 - ** Load capacity on standard speed and weight
-
- Our company is entitled to make any change on any information in this catalogue, without further notice.
 - This catalogue annuls all the previous catalogues
 - All figures are for reference; our company is not responsible for printing errors.



RM-60_{Trailer}

PERFORMANCE INFORMATION

Traction type trailer tire.



FEATURES

Long life

Suitable for short period transport along with field use.

Offers high resistance against lug fatigue and tread wear thanks to its specially developed tread compound and geometry.

Heavy load capacity / Self-cleaning

Special tread and carcass structure offer high load capacity.

SIZE 8.25-20

Trailer · Characteristics of **RM-60**

Tire Size	PR	TT/TL	Load/Speed Index	Rims		Inflated Dimensions (No Load)		Inflated Dimensions (W/Load)		Inflation Pressure (psi/bar)	Load capacity per tire, kg				
				Recom (inch)	Permitted (inch)	Section Width (mm)	Outer Diameter (mm)	Dynamic Rolling Circumference (mm)	Static Loaded Radius (mm)		Speed, km/h				
											10	20	25	30	40
8.25-20	14	TT	133/A6	6.00	5.00F	229	950	2910	435	72 / 5.0	2285	2020	1895	1770	1595
										78 / 5.4	2500	2207	2070	1935	1745
										90 / 6.2	2655	2350	2205	2060	1855

Load capacity on recommended speed and pressure is stated with dark colour.

DESCRIPTION

- * For load capacity on various speed ratings, and inflation figures, please consult your sales representative.
 - ** Load capacity on standard speed and weight
-
- Our company is entitled to make any change on any information in this catalogue, without further notice.
 - This catalogue annuls all the previous catalogues
 - All figures are for reference; our company is not responsible for printing errors.

RM-70 Trailer

PERFORMANCE INFORMATION

Traction type trailer tire.



FEATURES

Long life / Durability

Offers high resistance against lug fatigue and tread wear thanks to its specially developed tread compound and geometry.

Flexible carcass structure prevents sinking into the soil while protecting the tire by absorbing side impacts.

Heavy load capacity / Self-cleaning

Special tread and carcass structure offers high load capacity.

SIZE 9.00-20

Trailer · Characteristics of **RM-70**

Tire Size	PR	TT/TL	Load/Speed Index	Rims		Inflated Dimensions (No Load)		Inflated Dimensions (W/Load)		Inflation Pressure (psi/bar)	Load capacity per tire, kg				
				Recom (inch)	Permitted (inch)	Section Width (mm)	Outer Diameter (mm)	Dynamic Rolling Circumference (mm)	Static Loaded Radius (mm)		Speed, km/h				
											10	20	25	30	40
9.00-20	14	TT	133/A6	6.00F	5.50F, 6LB	254	1017	3040	452	67 / 4.6	2285	2020	1895	1770	1595
										72 / 5.0	2500	2207	2070	1935	1745
										81 / 5.6	2655	2350	2205	2060	1855

Load capacity on recommended speed and pressure is stated with dark colour.

DESCRIPTION

- * For load capacity on various speed ratings, and inflation figures, please consult your sales representative.
 - ** Load capacity on standard speed and weight
-
- Our company is entitled to make any change on any information in this catalogue, without further notice.
 - This catalogue annuls all the previous catalogues
 - All figures are for reference; our company is not responsible for printing errors.



SM-270 Trailer

PERFORMANCE INFORMATION

Traction type trailer tire with high resistance.



FEATURES

Long life

Reinforced sidewalls provide durability and protect the tire from side impacts.

Special tread depth and geometry offers high resistance to cuts and tread wear.

Heavy load capacity / Self-cleaning

High load capacity, outstanding self-cleaning feature.

SIZE 7.50-16

Trailer · Characteristics of **SM-270**

Tire Size	PR	TT/TL	Load/Speed Index	Rims		Inflated Dimensions (No Load)		Inflated Dimensions (W/Load)		Inflation Pressure (psi/bar)	Load capacity per tire, kg				
				Recom (inch)	Permitted (inch)	Section Width (mm)	Outer Diameter (mm)	Dynamic Rolling Circumference (mm)	Static Loaded Radius (mm)		Speed, km/h				
											10	20	25	30	40
7.50-16	12	TT	121/A6	5.50F	4.50E, 5.00F, 6.00F, 6LB	216	803	2370	354	52 / 3.6	1610	1420	1335	1245	1120
										58 / 4.0	1760	1555	1460	1360	1225
										73 / 5.0	1870	1650	1550	1450	1305

Load capacity on recommended speed and pressure is stated with dark colour.

DESCRIPTION

- * For load capacity on various speed ratings, and inflation figures, please consult your sales representative.
 - ** Load capacity on standard speed and weight
-
- Our company is entitled to make any change on any information in this catalogue, without further notice.
 - This catalogue annuls all the previous catalogues
 - All figures are for reference; our company is not responsible for printing errors.

SM-160 3 Rib Trailer

PERFORMANCE INFORMATION

The ideal trailer tire for high load capacity with minimum soil compaction.



FEATURES

Long service life / Durability

Reinforced carcass structure ensures longevity by improving resistance against cuts and wears.

Heavy load capacity / Self-cleaning

Offers high loading capacity with minimum soil compaction thanks to special three-rib tread design.
Offers excellent self-cleaning features.

SIZE 7.50-16

Trailer · Characteristics of **SM-160 3 Rib**

Tire Size	PR	TT/TL	Load/Speed Index	Rims		Inflated Dimensions (No Load)		Inflated Dimensions (W/Load)		Inflation Pressure (psi/bar)	Load capacity per tire, kg				
				Recom (inch)	Permitted (inch)	Section Width (mm)	Outer Diameter (mm)	Dynamic Rolling Circumference (mm)	Static Loaded Radius (mm)		Speed, km/h				
											10	20	25	30	40
7.50-16	10	TT	116/A6	5.50F	4.50E, 5.00F, 6.00F, 6LB	216	805	2375	356	46 / 3.2	1340	1180	1110	1040	935
										52 / 3.6	1465	1295	1215	1138	1025
										58 / 4.0	1615	1425	1340	1250	1125

Load capacity on recommended speed and pressure is stated with dark colour.

DESCRIPTION

* For load capacity on various speed ratings, and inflation figures, please consult your sales representative.

** Load capacity on standard speed and weight

- Our company is entitled to make any change on any information in this catalogue, without further notice.
- This catalogue annuls all the previous catalogues
- All figures are for reference; our company is not responsible for printing errors.



IMP-40_{Trailer}

PERFORMANCE INFORMATION

Efficient and dependable tire solution for implements and trailers, ideal for light fieldwork and transport operations under moderate conditions.



FEATURES

Multi-Environment Usability & Economic Value

Engineered to perform reliably on both paved roads and cultivated land.

Tailored for budget-conscious users engaging in low-intensity tasks.

Longevity & Gentle Soil Contact

Robust textile carcass delivers extended service life.

Specially built for use on land with minimal or no stubble, reducing impact on soil structure.

SIZES 10.0/75-15.3

Trailer · Characteristics of **IMP-40**

Tire Size	PR	TT/TL	Load/Speed Index	Rims		Inflated Dimensions (No Load)		Inflated Dimensions (W/Load)		Inflation Pressure (psi/bar)	Load capacity per tire, kg				
				Recom (inch)	Permitted (inch)	Section Width (mm)	Outer Diameter (mm)	Dynamic Rolling Circumference (mm)	Static Loaded Radius (mm)		Speed, km/h				
											10	20	25	30	40
10.0/75-15.3	10 RF	TL	123/A8	9.00	-	272	765	2379	361	47 / 3.2	1740	1640	1545	1380	1240
										53 / 3.6	1835	1735	1630	1460	1310
										57 / 3.8	1950	1845	1735	1550	1395
10.0/75-15.3	12 RF	TL	126/A8	9.00	-	272	765	2379	361	58 / 4.0	1780	1680	1580	1410	1270
										61 / 4.2	1950	1840	1730	1545	1390
										68 / 4.7	2140	2020	1905	1700	153
10.0/75-15.3	14	TL	130/A8	9.00	-	272	765	2379	361	68 / 4,7	2015	1900	1790	1600	1440
										73 / 5,0	2200	2080	1960	1750	1575
										80 / 5,5	2390	2260	2130	1900	171

Load capacity on recommended speed and pressure is stated with dark colour.

DESCRIPTION

- * For load capacity on various speed ratings, and inflation figures, please consult your sales representative.
- ** Load capacity on standard speed and weight

- Our company is entitled to make any change on any information in this catalogue, without further notice.
- This catalogue annuls all the previous catalogues
- All figures are for reference; our company is not responsible for printing errors.





IMP-80 ^{5 Rib} Trailer

■ PERFORMANCE INFORMATION

Modern harvester and trailer tire.



■ FEATURES

Long life / Durability

Special tread design and structure ensures high resistance against cuts and wears.

Perfect load capacity / Ultimate performance

Demonstrates low dynamic rotating resistance thanks to its 5 Rib design.

Suitable for short period transport and field use.

Wide base area prevents slides to sides and sinking into the soil.

■ SIZES

19.0/45-17 · 500/50-17 · 15.0/55-17 · 340/55-16 · 400/60-15.5 · 13.0/65-18 · 10.0/75-15
12.5/80-18 · 10.5/80-18 · 12.5/80-15.3 · 11.5/80-15.3

Trailer · Characteristics of **IMP-80 5 Rib**

Tire Size	PR	TT/TL	Load/Speed Index	Rims		Inflated Dimensions (No Load)		Inflated Dimensions (W/Load)		Inflation Pressure (psi/bar)	Load capacity per tire, kg				
				Recom (inch)	Permitted (inch)	Section Width (mm)	Outer Diameter (mm)	Dynamic Rolling Circumference (mm)	Static Loaded Radius (mm)		Speed, km/h				
											20	25	30	40	50
19.0/45-17	12	TL	141/A8	16.00	-	491	866	2615	388	30 / 2.1	2985	2820	2655	2370	2130
										33 / 2,3	3115	2940	2770	2470	2225
										36 / 2,5	3245	3065	2885	2575	2320
500/50-17	14	TL	149/A8	16.00	-	503	932	2846	420	44 / 3.0	3605	3400	3200	2860	2575
										48 / 3.3	3850	3635	3420	3055	2750
										51 / 3.5	4095	3870	3640	3250	2925
15.0/55-17	14	TL	137/A8	13.00	13	391	850	2467	370	44 / 3.0	2550	2410	2265	2025	1820
										49 / 3.4	2725	2575	2420	2160	1945
										52 / 3.6	2900	2735	2575	2300	2070
340/55-16	12	TL	140/A8	11	-	343	780	2325	735	49 / 3.4	2680	2530	2380	2125	1915
										52 / 3.6	2870	2705	2550	2275	2050
										58 / 4.0	3150	2975	2800	2500	2250
400/60-15.5	14	TL	145/A8	AG 13.00	-	404	874	2661	390	46 / 3,2	3365	3175	2990	2670	2400
										49 / 3,4	3505	3310	3120	2785	2505
										52 / 3,6	3655	3450	3250	2900	2610
										64 / 4,4	3680	3475	3270	2920	2630
										70 / 4,8	3760	3550	3345	2985	2690
75 / 5,2	3875	3660	3445	3075	2770										
13.0/65-18	14	TT	141/A8	11	-	336	890	2828	420	50 / 3.6	2790	2635	2480	2215	1995
										58 / 4.0	3050	2880	2710	2420	2180
										63 / 4.3	3245	3065	2885	2575	2320
10.0/75-15.3	10	TT	123/A8	9.00	-	264	760	2368	352	46 / 3.2	1740	1640	1545	1380	1240
										52 / 3.6	1835	1735	1630	1460	1310
										56 / 3.8	1950	1845	1735	1550	1395
	12 RF	TL	126/A8							58 / 4.0	1780	1680	1580	1410	1270
										61 / 4.2	1950	1840	1730	1545	1390
										68 / 4.7	2140	2020	1905	1700	1530
	14	TL	130/A8							68 / 4.7	2190	2070	1950	1740	1565
										73 / 5.0	2315	2190	2060	1840	1655
										80 / 5.5	2465	2325	2190	1955	1760

Load capacity on recommended speed and pressure is stated with dark colour.

RF: REINFORCED

DESCRIPTION

* For load capacity on various speed ratings, and inflation figures, please consult your sales representative.

** Load capacity on standard speed and weight

- Our company is entitled to make any change on any information in this catalogue, without further notice.
- This catalogue annuls all the previous catalogues
- All figures are for reference; our company is not responsible for printing errors.

Trailer · Characteristics of **IMP-80 5 Rib**

Tire Size	PR	TT/TL	Load/Speed Index	Rims		Inflated Dimensions (No Load)		Inflated Dimensions (W/Load)		Inflation Pressure (psi/bar)	Load capacity per tire, kg				
				Recom (inch)	Permitted (inch)	Section Width (mm)	Outer Diameter (mm)	Dynamic Rolling Circumference (mm)	Static Loaded Radius (mm)		Speed, km/h				
											20	25	30	40	50
12.5/80-18	14	TT	146/A8	W9	11	308	965	2915	431	55 / 3.8	3215	3035	2855	2550	2295
										61 / 4.2	3515	3320	3125	2790	2510
										65 / 4.5	3780	3570	3360	3000	2700
10.5/80-18	14	TT	142/A8	W9	W8-9	274	885	2748	412	55 / 3.8	2840	2680	2525	2255	2030
										61 / 4.2	3105	2935	2760	2465	2220
										65 / 4.5	3340	3155	2970	2650	2385
12.5/80-15.3	12	TL	139/A8	9.00	-	307	889	2571	378	45 / 3,1	2785	2630	2475	2210	1990
										49 / 3.4	2880	2720	2560	2285	2055
										54 / 3.7	3060	2890	2720	2430	2190
	12 RF	TL	139/A8							45 / 3,1	2785	2630	2475	2210	1990
										49 / 3.4	2880	2720	2560	2285	2055
										54 / 3.7	3060	2890	2720	2430	2190
	16	TL	144/A8							61 / 4,2	3350	3165	2980	2660	2395
										65 / 4,5	3420	3230	3040	2715	2445
										71 / 4,9	3530	3330	3135	2800	2520
11.5/80-15.3	12	TT	135/A8	9.00	-	290	845	2600	382	49 / 3.4	2335	2205	2075	1855	1670
										55 / 3.8	2530	2390	2245	2005	1805
										60 / 4.1	2750	2595	2440	2180	1960
	12	TL	135/A8							49 / 3.4	2335	2205	2075	1855	1670
										55 / 3.8	2530	2390	2245	2005	1805
										60 / 4.1	2750	2595	2440	2180	1960
	12 RF	TL	135/A8							49 / 3.4	2335	2205	2075	1855	1670
										55 / 3.8	2530	2390	2245	2005	1805
										60 / 4.1	2750	2595	2440	2180	1960
	14	TL	139/A8							58 / 4,0	2600	2460	2315	2065	1840
										64 / 4,4	2785	2630	2475	2210	1970
										69 / 4.8	3060	2890	2720	2430	2160

Load capacity on recommended speed and pressure is stated with dark colour.

RF: REINFORCED

DESCRIPTION

* For load capacity on various speed ratings, and inflation figures, please consult your sales representative.

** Load capacity on standard speed and weight

- Our company is entitled to make any change on any information in this catalogue, without further notice.
- This catalogue annuls all the previous catalogues
- All figures are for reference; our company is not responsible for printing errors.





IMP-90_{Trailer}

PERFORMANCE INFORMATION

General purpose trailer tire.



FEATURES

Long service life / Durability

High resistance against cuts and wear with specially designed tread geometry.

Heavy load capacity / High performance

Special tread and carcass structure offers high load capacity.

Provides high traction and leads to less soil compaction with its wide base area.

Provides perfect balance on soft terrains by preventing slide to sides.

SIZES

11.5/80-15.3 RF · 12.5/80-15.3 RF · 10.0/75-15.3 RF · 260/70-15.3

Trailer · Characteristics of IMP-90

Tire Size	PR	TT/TL	Load/Speed Index	Rims		Inflated Dimensions (No Load)		Inflated Dimensions (W/Load)		Inflation Pressure (psi/bar)	Load capacity per tire, kg				
				Recom (inch)	Permitted (inch)	Section Width (mm)	Outer Diameter (mm)	Dynamic Rolling Circumference (mm)	Static Loaded Radius (mm)		Speed, km/h				
											20	25	30	40	50
11.5/80-15.3 RF	12	TL	137/A8	9.00	-	290	845	2506	376	46 / 3.2	2465	2325	2190	1955	1760
										52 / 3.6	2665	2520	2370	2115	1905
										60 / 4.1	2900	2735	2575	2300	2070
12.5/80-15.3 RF	12	TL	141/A8	9.00	-	370	889	2630	386	45 / 3,1	2950	2790	2625	2345	2110
										49 / 3.4	3050	2880	2710	2420	2180
										54 / 3.7	3245	3064	2884	2575	2320
10.0/75-15.3 RF	12	TL	126/A8	9.00	-	264	760	2360	348	58 / 4.0	1780	1680	1580	1410	1270
										61 / 4.2	1950	1840	1735	1550	1390
										68 / 4.7	2140	2025	1905	1700	1530
260/70-15.3	12	TL	126/A8	9.00	-	268	753	2245	335	46 / 3.2	1885	1780	1675	1495	1345
										49 / 3.4	2015	1900	1790	1600	1440
										52 / 3.6	2145	2025	1905	1700	1530

Load capacity on recommended speed and pressure is stated with dark colour.

RF: REINFORCED

DESCRIPTION

* For load capacity on various speed ratings, and inflation figures, please consult your sales representative.

** Load capacity on standard speed and weight

- Our company is entitled to make any change on any information in this catalogue, without further notice.
- This catalogue annuls all the previous catalogues
- All figures are for reference; our company is not responsible for printing errors.



IMP-100 Trailer

PERFORMANCE INFORMATION

General purpose trailer tire.



FEATURES

Long service life / Durability

High resistance against cuts and tread wear with special tread geometry design.

Heavy load capacity / High performance

Special tread and carcass structure offers high load capacity.

It squeezes less soil with its wide base area, so provides high traction on soft terrains.

It provides perfect balance on soft surfaces by preventing slide to sides.

SIZES 10.0/80-12 RF

Trailer · Characteristics of **IMP-100**

Tire Size	PR	TT/TL	Load/Speed Index	Rims		Inflated Dimensions (No Load)		Inflated Dimensions (W/Load)		Inflation Pressure (psi/bar)	Load capacity per tire, kg				
				Recom (inch)	Permitted (inch)	Section Width (mm)	Outer Diameter (mm)	Dynamic Rolling Circumference (mm)	Static Loaded Radius (mm)		Speed, km/h				
											20	25	30	40	50
10.0/80-12 RF	10	TT	122/A8	W8	7.00-9.00	280	710	2130	316	48 / 3.3	1665	1570	1480	1320	1190
										52 / 3.6	1775	1680	1580	1410	1270
										57 / 3.9	1890	1785	1680	1500	1350
		TL								48 / 3.3	1665	1570	1480	1320	1190
										52 / 3.6	1775	1680	1580	1410	1270
										57 / 3.9	1890	1785	1680	1500	1350

Load capacity on recommended speed and pressure is stated with dark colour.

RF: REINFORCED

DESCRIPTION

- * For load capacity on various speed ratings, and inflation figures, please consult your sales representative.
 - ** Load capacity on standard speed and weight
-
- Our company is entitled to make any change on any information in this catalogue, without further notice.
 - This catalogue annuls all the previous catalogues
 - All figures are for reference; our company is not responsible for printing errors.





IMP-110 Trailer

PERFORMANCE INFORMATION

Trailer tire designed for free rolling axle.



FEATURES

Long service life / Durability

Outstanding resistance against stubble punctures and cuts with its special tread compound.

Heavy load capacity / High performance

Offers heavy load capacity and long service life with its durable carcass structure design.

Special Low Section Height profile design ensures high performance.

Wide tread design provides high flotation capability.

SIZES 9.5L-14SL · 9.5L-15SL · 11L-15SL · 12.5L-15SL

Trailer · Characteristics of **IMP-110**

Tire Size	PR	TT/TL	Load/Speed Index	Rims		Inflated Dimensions (No Load)		Inflated Dimensions (W/Load)		Inflation Pressure (psi/bar)	Load Capacity Per Tire (kg)
				Recom (inch)	Permitted (inch)	Section Width (mm)	Outer Diameter (mm)	Dynamic Radius Cycle (mm)	Radius (mm)		Speed (km/h)
9.5L-14SL	8	TL	111 B	7LB	8LB	248	743	2192	337	44/3.0	1090
9.5L-15SL	8	TL	112 B	7LB	8LB	250	765	2257	344	44/3.0	1120
	8	TT	112 B							44/3.0	1120
	12	TL	121 B							64/4.40	1450
11L-15SL	8	TL	113 B	8LB	10LB	273	780	2293	350	36/2.50	1150
	12	TL	121 B							52/3.60	1450
12.5L-15SL	12	TL	127 B	10LB	-	325	825	2430	371	52/3.60	1750

Load capacity on recommended speed and pressure is stated with dark colour.

DESCRIPTION

- * For load capacity on various speed ratings, and inflation figures, please consult your sales representative.
 - ** Load capacity on standard speed and weight
-
- Our company is entitled to make any change on any information in this catalogue, without further notice.
 - This catalogue annuls all the previous catalogues
 - All figures are for reference; our company is not responsible for printing errors.



IMP-70 Trailer

PERFORMANCE INFORMATION

Trailer tire.



FEATURES

Long life

Stable central tread section with open shoulder design enhances comfort and improves longevity.

Strong sidewall construction and durable bead structure provides excellent protection against all kinds of damage.

Perfect load capacity / Ultimate performance

Offers excellent floatation and self-cleaning features..

Low rolling resistance leads to maximum efficiency in fuel consumption.

SIZES 16.0/70-20 · 400/70-20

Trailer · Characteristics of IMP-70

Tire Size	PR	TT/TL	Load/Speed Index	Rims		Inflated Dimensions (No Load)		Inflated Dimensions (W/Load)		Inflation Pressure (psi/bar)	Load capacity per tire, kg				
				Recom (inch)	Permitted (inch)	Section Width (mm)	Outer Diameter (mm)	Dynamic Rolling Circumference (mm)	Static Loaded Radius (mm)		Speed, km/h				
											20	25	30	40	50
16.0/70-20	14	TL	154 A8 / 142 A8	13	12 SDC, 13 SDC, 14	418	1075	475	3160	44 / 3.0	4160	3930	3695	3300	2970
										48 / 3.3	4445	4200	3950	3525	3175
										51 / 3.5	4725	4465	4200	3750	3375
400/70-20	14	TL	154 A8 / 142 A8	13 SDC	13, 14	418	1068	472	3140	41 / 2.8	4395	4155	3910	3490	3140
										44 / 3.0	4535	4285	4035	3600	3240
										46 / 3.2	4725	4465	4200	3750	3375

Load capacity on recommended speed and pressure is stated with dark colour.

DESCRIPTION

- * For load capacity on various speed ratings, and inflation figures, please consult your sales representative.
 - ** Load capacity on standard speed and weight
-
- Our company is entitled to make any change on any information in this catalogue, without further notice.
 - This catalogue annuls all the previous catalogues
 - All figures are for reference; our company is not responsible for printing errors.





IMP-60_{Trailer}

■ PERFORMANCE INFORMATION

Free rolling tire designed to use on agricultural trailers and balers.



■ FEATURES

Heavy load capacity / Durability

Even under low air pressure and heavy load, delivers durability thanks to its strong carcass structure.

Ultimate performance / Fuel Efficiency

Offers flotation as rounded shoulders and wider base spread load on the surface. Protect crops with low soil compaction feature. Enables driving comfort and fuel efficiency.

Self-cleaning

Delivers excellent self-cleaning capability thanks to its wide grooves.

■ SIZE 500/50-17

Trailer · Characteristics of IMP-60

Tire Size	PR	TT/TL	Speed/Load Index		Rims		Inflated Dimensions (No Load)		Inflated Dimensions (W/Load)		Inflation Pressure (psi/bar)	Load capacity per tire, kg									
			Free Rolling Axle	Steer Axle	Recom (inch)	Permitted (inch)	Section Width (inch)	Outer Diameter (mm)	Dynamic Rolling Circumference (mm)	Static Loaded Radius (mm)		Free Rolling Axle (kg)					Steer Axle (kg)				
												10	25	30	40	50	10	25	30	40	50
500/50-17	16	TL	152/A8	139/A8	16.00	-	503	932	2760	410	39 / 2.7	4520	3845	3620	3230	2910	3095	2630	2475	2210	1990
											43 / 3.0	4770	4055	3815	3410	3070	3265	2775	2610	2330	2100
											48 / 3.2	4970	4225	3975	3550	3195	3400	2890	2720	2430	2190

Load capacity on recommended speed and pressure is stated with dark colour.

DESCRIPTION

* For load capacity on various speed ratings, and inflation figures, please consult your sales representative.

** Load capacity on standard speed and weight

- Our company is entitled to make any change on any information in this catalogue, without further notice.
- This catalogue annuls all the previous catalogues
- All figures are for reference; our company is not responsible for printing errors.



SR-3 Trailer

■ PERFORMANCE INFORMATION

Trailer tire designed for free rolling axle.



■ FEATURES

Long service life / Durability

Special tread compound provides excellent resistance against stubble punctures and cuts.

Durable carcass structure improves longevity.

Heavy load capacity / High performance

Ensures high performance with its Low Section Height profile design.

Delivers high flotation capability thanks to its wide tread design.

Special carcass design supports heavy load capacity.

■ SIZES 10.0/75-15.3

Trailer · Characteristics of **SR-3**

Tire Size	PR	TT/TL	Load/Speed Index	Rims		Inflated Dimensions (No Load)		Inflated Dimensions (W/Load)		Inflation Pressure (psi/bar)	Load capacity per tire, kg					
				Recom (inch)	Permitted (inch)	Section Width (mm)	Outer Diameter (mm)	Dynamic Rolling Circumference (mm)	Static Loaded Radius (mm)		Speed, km/h					
											10	20	25	30	40	
10.0/75-15.3	12	TL	126/A8	9.00	-	264	760	2240	346	58 / 4.0	1780	1680	1580	1410	1270	
											61 / 4.2	1950	1840	1735	1550	1390
											68 / 4.7	2140	2025	1905	1700	1530

Load capacity on recommended speed and pressure is stated with dark colour.

DESCRIPTION

* For load capacity on various speed ratings, and inflation figures, please consult your sales representative.

** Load capacity on standard speed and weight

- Our company is entitled to make any change on any information in this catalogue, without further notice.
- This catalogue annuls all the previous catalogues
- All figures are for reference; our company is not responsible for printing errors.

SM-350 Trailer

■ PERFORMANCE INFORMATION

Trailer implement tire that offers high performance.



■ FEATURES

Performance & Flotation

Ensures high performance with its Low Section Height profile design.

Delivers high flotation capability thanks to its wide tread design.

Durability & Load Capacity

Special carcass design supports heavy load capacity.

Durable carcass structure improves longevity.

Special tread compound provides excellent resistance against stubble punctures and cuts.

■ SIZES 7.50-16

Trailer · Characteristics of **SM-350**

Tire Size	PR	TT/TL	Load/Speed Index	Rims		Inflated Dimensions (No Load)		Inflated Dimensions (W/Load)		Inflation Pressure (psi/bar)	Load capacity per tire, kg				
				Recom (inch)	Permitted (inch)	Section Width (mm)	Outer Diameter (mm)	Dynamic Rolling Circumference (mm)	Static Loaded Radius (mm)		Speed, km/h				
											10	20	25	30	40
7.50-16	12	TT	121/A6	5.50F	4.50E, 5.00F, 6.00F, 6LB	214	803	2375	356	52 / 3.6	1610	1420	1335	1245	1120
										58 / 4.0	1760	1555	1460	1360	1225
										73 / 5.0	1870	1650	1550	1450	1305

Load capacity on recommended speed and pressure is stated with dark colour.

DESCRIPTION

- * For load capacity on various speed ratings, and inflation figures, please consult your sales representative.
 - ** Load capacity on standard speed and weight
-
- Our company is entitled to make any change on any information in this catalogue, without further notice.
 - This catalogue annuls all the previous catalogues
 - All figures are for reference; our company is not responsible for printing errors.



Harvester
Radial /
Harvester

TR-130 RADIAL
AGROVEST

SB-140 RADIAL
AGROVEST

IMP-70 HARVESTER

TR-90

TR-95

TR-330

IMP-80 HARVESTER



TR-130

SB-140

IMP-70

TR-90

TR-95

TR-330

IMP-80

ERVES





TR-130

AGROVEST *Aramid Belted* Radial Harvester

PERFORMANCE INFORMATION

R-1W Harvester tire with aramid belted structure.



Innovative Construction

Special tread design enables exceptional traction and better handling on field and tillage operations.

FEATURES

Long life

Special tread compound offers high resistance against punctures.

Perfect performance under heavy loads with lower pressure compared to traditional radial tire construction.

Low soil compaction

Wider footprint and optimized lug angle minimize soil compaction and avoid crop damage.

Elastic structure absorbs impacts and yields better flotation.

Aramid belt technology provides extra protection against stubble damage and ground impacts compared to steel and fabric alternatives.

Reinforced bead structure ensures long life by improving the tire's endurance.

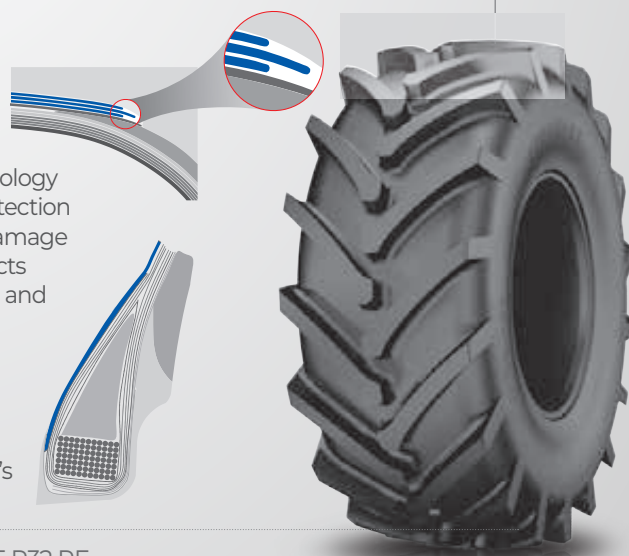

SIZES

620/75 R26 · 620/75 R30 · 650/75 R32 · 650/75 R32 RF
800/65 R32 · 800/65 R32 RF

Radial Harvester · Characteristics of **TR-130 AGROVEST**

Tire Size	TT/TL	Load/Speed Index	Rims		Inflated Dimensions (No Load)		Inflated Dimensions (W/Load)		Inflation Pressure (psi/bar)	Load capacity per tire, kg				Extra Features
			Recom (inch)	Permitted (inch)	Section Width (mm)	Outer Diameter (mm)	Dynamic Rolling Circumference (mm)	Static Loaded Radius (mm)		Speed, km/h				
										10	30	40	50	
620/75 R26	TL	166 A8/163 B	DW 20B	-	649	1565	4614	692	17 / 1,2	4190	3345	3125	3125	Aramid Belt
									20 / 1,4	4685	3745	3500	3500	
									23 / 1,6	5115	4085	3815	3815	
									26 / 1,8	5325	4255	3975	3975	
									29 / 2,0	5610	4480	4185	4185	
									32 / 2,2	5825	4650	4345	4345	
									35 / 2,4	6035	4820	4505	4505	
									38 / 2,6	6320	5045	4715	4715	
									41 / 2,8	6605	5275	4930	4930	
									44 / 3,0	6820	5445	5090	5090	
								46 / 3,2	7100	5670	5300	5300		
620/75 R26	TL	166 A8/B	DW 20B	-	636	1573	4634	695	17 / 1,2	4190	3345	3125	3125	Aramid Belt
									20 / 1,4	4685	3745	3500	3500	
									23 / 1,6	5115	4085	3815	3815	
									26 / 1,8	5325	4255	3975	3975	
									29 / 2,0	5610	4480	4185	4185	
									32 / 2,2	5825	4650	4345	4345	
									35 / 2,4	6035	4820	4505	4505	
									38 / 2,6	6320	5045	4715	4715	
									41 / 2,8	6605	5275	4930	4930	
									44 / 3,0	6820	5445	5090	5090	
								46 / 3,2	7100	5670	5300	5300		
620/75 R30	TL	169 A8/B	DW 20B	-	623	1693	5022	753	17 / 1,2	4585	3660	3420	3420	Aramid Belt
									20 / 1,4	5130	4095	3830	3830	
									23 / 1,6	5595	4470	4175	4175	
									26 / 1,8	5830	4655	4350	4350	
									29 / 2,0	6140	4905	4580	4580	
									32 / 2,2	6375	5090	4755	4755	
									35 / 2,4	6605	5275	4930	4930	
									38 / 2,6	6915	5525	5160	5160	
									41 / 2,8	7230	5770	5395	5395	
									44 / 3,0	7460	5960	5570	5570	
								46 / 3,2	7770	6205	5800	5800		

Load capacity on recommended speed and pressure is stated with dark colour.

DESCRIPTION

- * For load capacity on various speed ratings, and inflation figures, please consult your sales representative.
 - ** Load capacity on standard speed and weight
-
- Our company is entitled to make any change on any information in this catalogue, without further notice.
 - This catalogue annuls all the previous catalogues
 - All figures are for reference; our company is not responsible for printing errors.



Radial Harvester · Characteristics of **TR-130 AGROVEST**

Tire Size	TT/TL	Load/Speed Index	Rims		Inflated Dimensions (No Load)		Inflated Dimensions (W/Load)		Inflation Pressure (psi/bar)	Load capacity per tire, kg				Extra Features
			Recom (inch)	Permitted (inch)	Section Width (mm)	Outer Diameter (mm)	Dynamic Rolling Circumference (mm)	Static Loaded Radius (mm)		Speed, km/h				
										10	30	40	50	
620/75 R30	TL	169 A8/B	DW 20B	-	638	1678	4982	747	17/1,2	4585	3660	3420	3420	
									20/1,4	5130	4095	3830	3830	
									23/1,6	5595	4470	4175	4175	
									26/1,8	5830	4655	4350	4350	
									29/2,0	6140	4905	4580	4580	
									32/2,2	6375	5090	4755	4755	
									35/2,4	6605	5275	4930	4930	
									38/2,6	6915	5525	5160	5160	
									41/2,8	7230	5770	5395	5395	
									44/3,0	7460	5960	5570	5570	
								46/3,2	7770	6205	5800	5800		
650/75 R32	TL	172 A8/B	DW 20B	DW20B DW23B	658	1778	5284	792	17/1,2	4980	3975	3715	3715	
									20/1,4	5570	4450	4160	4160	
									23/1,6	6080	4855	4535	4535	
									26/1,8	6330	5055	4725	4725	
									29/2,0	6670	5325	4975	4975	
									32/2,2	6920	5530	5165	5165	
									35/2,4	7175	5730	5355	5355	
									38/2,6	7515	6000	5605	5605	
									41/2,8	7850	6270	5860	5860	
									44/3,0	8105	6470	6050	6050	
								46/3,2	8440	6740	6300	6300		
650/75 R32 RF	TL	172 A8/B	DW 20B	DW20B DW23B	658	1777	5282	792	17/1,2	4980	3975	3715	3715	Aramid Belt
									20/1,4	5570	4450	4160	4160	
									23/1,6	6080	4855	4535	4535	
									26/1,8	6330	5055	4725	4725	
									29/2,0	6670	5325	4975	4975	
									32/2,2	6920	5530	5165	5165	
									35/2,4	7175	5730	5355	5355	
									38/2,6	7515	6000	5605	5605	
									41/2,8	7850	6270	5860	5860	
									44/3,0	8105	6470	6050	6050	
								46/3,2	8440	6740	6300	6300		

Load capacity on recommended speed and pressure is stated with dark colour.

Radial Harvester · Characteristics of **TR-130 AGROVEST**

Tire Size	TT/TL	Load/Speed Index	Rims		Inflated Dimensions (No Load)		Inflated Dimensions (W/Load)		Inflation Pressure (psi/bar)	Load capacity per tire, kg				Extra Features
			Recom (inch)	Permitted (inch)	Section Width (mm)	Outer Diameter (mm)	Dynamic Rolling Circumference (mm)	Static Loaded Radius (mm)		Speed, km/h				
										10	30	40	50	
800/65 R32	TL	178 A8/B	DW27B	DW25B DH27B	785	1870	5529	829	17 / 1,2	5930	4735	4425	4425	
									20 / 1,4	6635	5295	4950	4950	
									23 / 1,6	7235	5780	5400	5400	
									26 / 1,8	7540	6020	5625	5625	
									29 / 2,0	7940	6340	5925	5925	
									32 / 2,2	8240	6580	6150	6150	
									35 / 2,4	8545	6820	6375	6375	
									38 / 2,6	8945	7140	6675	6675	
									41 / 2,8	9345	7465	6975	6975	
									44 / 3,0	9650	7705	7200	7200	
								46 / 3,2	10050	8025	7500	7500		
800/65 R32 RF	TL	178 A8/B	DW27B	DW25B DH27B	794	1855	5489	823	17 / 1,2	5930	4735	4425	4425	Aramid Belt
									20 / 1,4	6635	5295	4950	4950	
									23 / 1,6	7235	5780	5400	5400	
									26 / 1,8	7540	6020	5625	5625	
									29 / 2,0	7940	6340	5925	5925	
									32 / 2,2	8240	6580	6150	6150	
									35 / 2,4	8545	6820	6375	6375	
									38 / 2,6	8945	7140	6675	6675	
									41 / 2,8	9345	7465	6975	6975	
									44 / 3,0	9650	7705	7200	7200	
								46 / 3,2	10050	8025	7500	7500		

Load capacity on recommended speed and pressure is stated with dark colour.

RF: REINFORCED

DESCRIPTION

- * For load capacity on various speed ratings, and inflation figures, please consult your sales representative.
- ** Load capacity on standard speed and weight

- Our company is entitled to make any change on any information in this catalogue, without further notice.
- This catalogue annuls all the previous catalogues
- All figures are for reference; our company is not responsible for printing errors.



SB-140 AGROVEST Radial Harvester

PERFORMANCE INFORMATION

Modern radial harvester tire.



FEATURES

Long life

Special tread compound extends service life regardless of the softness or hardness of the ground.

Strong construction not only improves the tire's endurance, but also provides excellent performance.

High traction

Offers outstanding traction on hard and soft terrains.

Low rolling resistance feature improves efficiency in fuel consumption.

Low soil compaction

Offers high load capacity and minimum soil compaction.

SIZE 400/70 R20

Radial Harvester · Characteristics of **SB-140 AGROVEST**

Tire Size	TT/TL	Load/Speed Index	Rims		Inflated Dimensions (No Load)		Inflated Dimensions (W/Load)		Inflation Pressure (psi/bar)	Load capacity per tire, kg				
			Recom (inch)	Permitted (inch)	Section Width (mm)	Outer Diameter (mm)	Dynamic Rolling Circumference (mm)	Static Loaded Radius (mm)		Speed, km/h				
										20	25	30	40	50
400/70 R20	TL	185 A8 / 146 A8	13	12 SDC, 13 SDC, 14	404	1068	3150	468	44 / 3.0	4875	4605	4330	3870	3480
									46 / 3.2	5035	4755	4475	3995	3595
									52 / 3.6	5355	5060	4760	4250	3825

Load capacity on recommended speed and pressure is stated with dark colour.

DESCRIPTION

- * For load capacity on various speed ratings, and inflation figures, please consult your sales representative.
 - ** Load capacity on standard speed and weight
-
- Our company is entitled to make any change on any information in this catalogue, without further notice.
 - This catalogue annuls all the previous catalogues
 - All figures are for reference; our company is not responsible for printing errors.





IMP-70 Harvester

■ PERFORMANCE INFORMATION

Harvester rear and trailer tire.



■ FEATURES

Long life

Stable central tread section with open shoulder design enhances comfort and improves longevity.

Strong sidewall construction and durable bead structure provides excellent protection against all kinds of damage.

Perfect load capacity / Ultimate performance

Offers excellent flotation and self-cleaning features.

Low rolling resistance leads to maximum efficiency in fuel consumption.

■ SIZES 16.0/70-20 · 400/70-20



Harvester · Characteristics of **IMP-70**

Tire Size	TT/TL	Load/Speed Index	Rims		Inflated Dimensions (No Load)		Inflated Dimensions (W/Load)		Inflation Pressure (psi/bar)	Load capacity per tire, kg					
			Recom (inch)	Permitted (inch)	Section Width (mm)	Outer Diameter (mm)	Dynamic Rolling Circumference (mm)	Static Loaded Radius (mm)		Speed, km/h					
										20	25	30	40	50	
16.0/70-20	14	TL	154 A8/142 A8	13	12 SDC, 13 SDC, 14	418	1075	3160	475	44/3.0	4160	3930	3695	3300	2970
										48/3.3	4445	4200	3950	3525	3175
										51/3.5	4725	4465	4200	3750	3375
400/70-20	14	TL	154 A8/142 A8	13 SDC	13, 14	418	1068	3140	472	41/2.8	4395	4155	3910	3490	3140
										44/3.0	4535	4285	4035	3600	3240
										46/3.2	4725	4465	4200	3750	3375

Load capacity on recommended speed and pressure is stated with dark colour.

DESCRIPTION

- * For load capacity on various speed ratings, and inflation figures, please consult your sales representative.
 - ** Load capacity on standard speed and weight
-
- Our company is entitled to make any change on any information in this catalogue, without further notice.
 - This catalogue annuls all the previous catalogues
 - All figures are for reference; our company is not responsible for printing errors.





TR-90 Harvester

PERFORMANCE INFORMATION

Harvester tire.



FEATURES

Long life

Offers outstanding comfort and excellent traction throughout its service life thanks to its aggressive lug design.

Special tread compound and strong durable carcass structure provide high resistance against cuts and wears.

High Traction

Offers maximum cost efficiency in terms of both field and road performance.

Suitable for heavy duty operations without causing any damage to the crops.

Self-cleaning

Unique lug geometry keeps the tread pattern free from mud.

SIZE 18.4-30

Harvester · Characteristics of TR-90

Tire Size	PR	TT/TL	Load/Speed Index	Rims		Inflated Dimensions (No Load)		Inflated Dimensions (W/Load)		Inflation Pressure (psi/bar)	Load capacity per tire, kg					
				Recom (inch)	Permitted (inch)	Section Width (mm)	Outer Diameter (mm)	Dynamic Rolling Circumference (mm)	Static Loaded Radius (mm)		Speed, km/h					
											10	15	20	25	30	40
18.4-30	16	TT	153/A6	W16L	W15L	465	1535	4590	690	32 / 2.2	4055	3765	3420	3100	2895	2555
										35 / 2.4	4395	4080	3700	3355	3140	2765
										38 / 2.6	4830	4485	4070	3690	3450	3040
										33 / 2.3	4650	4320	3920	3555	3320	2920
										36 / 2.5	4805	4460	4045	3670	3430	3015
										45 / 2.9	5110	4745	4305	3905	3650	3210

Load capacity on recommended speed and pressure is stated with dark colour.

DESCRIPTION

* For load capacity on various speed ratings, and inflation figures, please consult your sales representative.

** Load capacity on standard speed and weight

- Our company is entitled to make any change on any information in this catalogue, without further notice.
- This catalogue annuls all the previous catalogues
- All figures are for reference; our company is not responsible for printing errors.





TR-95 Harvester

■ PERFORMANCE INFORMATION

Harvester tire.



■ FEATURES

Long life / Durability

Strong durable carcass structure and special tread compound improve resistance against cuts and wears.

High Traction / Self-cleaning

Unique lug design and geometry offer outstanding traction and self-cleaning features.

High load capacity

Strong carcass structure supports high load capacity.

■ **SIZE** 23.1-26 · 23.1-30 · 20.8-38

Harvester · Characteristics of TR-95

Tire Size	PR	TT/TL	Load/Speed Index	Rims		Inflated Dimensions (No Load)		Inflated Dimensions (W/Load)		Inflation Pressure (psi/bar)	Load capacity per tire, kg					
				Recom (inch)	Permitted (inch)	Section Width (mm)	Outer Diameter (mm)	Dynamic Rolling Circumference (mm)	Static Loaded Radius (mm)		Speed, km/h					
											10	15	20	25	30	40
23.1-26	12	TT	153/A6	DW20B	-	590	1650	4910	740	20/1.4	4290	3980	3630	3275	3060	2685
										22/1.5	4650	4320	3940	3545	3320	2910
	25/1.7	5110	4745							4330	3900	3650	3200			
	26/1.8	4700	4365							3965	3595	3360	2955			
	28/1.9	5150	4780							4340	3935	3680	3235			
	29/2.0	5600	5200							4720	4280	4000	3520			
	32/2.2	5565	5245							4760	4315	4035	3550			
	35/2.4	6090	5740							5210	4720	4415	3885			
	18	TL	162/A6							38/2.6	6550	6175	5605	5080	4750	4180
23.1-30	12	TT	151/A6	DW20B	-	592	1710	5090	770	20/1.4	4150	3855	3500	3170	2965	2610
										22/1.5	4440	4125	3740	3395	3170	2790
	25/1.7	4830	4485							4070	3690	3450	3035			
	26/1.8	4410	4095							3715	3365	3150	2770			
	28/1.9	4830	4485							4070	3685	3450	3035			
	29/2.0	5250	4875							4425	4010	3750	3300			
	32/2.2	5290	4915							4460	4045	3780	3325			
	35/2.4	5795	5380							4885	4430	4140	3645			
	18	TL	160/A6							38/2.6	6300	5850	5310	4815	4500	3960
20.8-38	14	TT	159/A6	W18L	W16L	545	1836	5550	848	29/2.0	5084	4720	4283	3885	3630	3195
										32/2.2	5515	5120	4645	4212	3935	3465
	34/2.3	6125	5688							5160	4680	4375	3850			
	29/2.0	5084	4720							4283	3885	3630	3195			
	32/2.2	5515	5120							4645	4212	3935	3465			
	34/2.3	6125	5688							5160	4680	4375	3850			
	33/2.3	5870	5450							5030	4485	4190	3770			
	36/2.5	6210	5765							5320	4745	4440	3990			
	39/2.7	6825	6335							5850	5215	4875	4385			
	33/2.3	5870	5450							5030	4485	4190	3770			
36/2.5	6210	5765	5320	4745	4440	3990										
	16	TT	163/A6							39/2.7	6825	6335	5850	5215	4875	4385
	16	TL	163/A6													

Load capacity on recommended speed and pressure is stated with dark colour.

DESCRIPTION

- * For load capacity on various speed ratings, and inflation figures, please consult your sales representative.
- ** Load capacity on standard speed and weight

- Our company is entitled to make any change on any information in this catalogue, without further notice.
- This catalogue annuls all the previous catalogues
- All figures are for reference; our company is not responsible for printing errors.



TR-330 Harvester

■ PERFORMANCE INFORMATION

R-1 tire designed for harvester applications.



■ FEATURES

Long life / Durability

Specially developed tread compound and lug geometry offer high resistance against lug fatigue and tread wear.

Reinforced sidewalls enhances durability against cuts and impacts.

High traction / Self-cleaning

Specially designed tread pattern provides superior traction with minimum soil compaction without causing any damage on the crops.

Optimum lug frequency reduces vibration.

Safety on inclined fields

Offers high load capacity.

■ SIZE 30.5L-32

Harvester · Characteristics of **TR-330**

Tire Size	PR	TT/TL	Load/Speed Index	Rims		Inflated Dimensions (No Load)		Inflated Dimensions (W/Load)		Inflation Pressure (psi/bar)	Load capacity per tire, kg			
				Recom (inch)	Permitted (inch)	Section Width (mm)	Outer Diameter (mm)	Dynamic Rolling Circumference (mm)	Static Loaded Radius (mm)		Speed, km/h			
											10	20	30	40
30.5L-32	18	TL	170/A6	DW 27B	DHB27, DH27B, DH27H	770	1819	5420	820	30 / 21	8400	7200	6000	5400

Load capacity on recommended speed and pressure is stated with dark colour.

DESCRIPTION

- * For load capacity on various speed ratings, and inflation figures, please consult your sales representative.
 - ** Load capacity on standard speed and weight
-
- Our company is entitled to make any change on any information in this catalogue, without further notice.
 - This catalogue annuls all the previous catalogues
 - All figures are for reference; our company is not responsible for printing errors.





IMP-80 Harvester

■ PERFORMANCE INFORMATION

Modern harvester tire.



■ FEATURES

Long life / Durability

Special tread design and structure ensures high resistance against cuts and wears.

Perfect load capacity / Ultimate performance

Demonstrates low dynamic rotating resistance thanks to its 5 Rib design.

Suitable for short period transport and field use.

Wide tread contact area prevents slides to sides and sinking into the soil.

■ SIZES 12.5/80-15.3

Harvester · Characteristics of **IMP-80**

Tire Size	PR	TT/TL	Load/Speed Index	Rims		Inflated Dimensions (No Load)		Inflated Dimensions (W/Load)		Inflation Pressure (psi/bar)	Load capacity per tire, kg				
				Recom (inch)	Permitted (inch)	Section Width (mm)	Outer Diameter (mm)	Dynamic Rolling Circumference (mm)	Static Loaded Radius (mm)		Speed, km/h				
											20	25	30	40	50
12.5/80-15.3	12	TL	139/A8	9.00	11	307	889	2571	378	45 / 3,1	2785	2630	2475	2210	1990
										49 / 3,4	2880	2720	2560	2285	2055
										54 / 3,7	3060	2890	2720	2430	2190
	61 / 4,2	3350	3165							2980	2660	2395			
	65 / 4,5	3420	3230							3040	2715	2445			
16	TL	144/A8	71 / 4,9	3530	3330	3135	2800	2520							

Load capacity on recommended speed and pressure is stated with dark colour.

DESCRIPTION

- * For load capacity on various speed ratings, and inflation figures, please consult your sales representative.
- ** Load capacity on standard speed and weight

- Our company is entitled to make any change on any information in this catalogue, without further notice.
- This catalogue annuls all the previous catalogues
- All figures are for reference; our company is not responsible for printing errors.

Flotation
Forestry

SM-F18
ST-FLOT
ST-HAUL
SMT-08
SMT-18



SM-F18

SMT-18

ST-FLOT

ST-HAUL

SMT-08





SM-F18 Flotation

PERFORMANCE INFORMATION

General purpose flotation tire.



FEATURES

Long life

Special sidewall compound protects the tire by effectively absorbing side impacts.

Perfect load capacity / Ultimate performance

Non-aggressive pattern is designed to ensure perfect balance with excellent grip on even the softest terrains and offer larger footprint to minimize soil compaction.

Strong tread and shoulder structure enable high load capacity.

SIZES 12.5/80-15.3 • 12.5/80-15.3 RF • 400/60-15.5 • 500/60-22.5 • 550/60-22.5 • 600/50-22.5

Flotation · Characteristics of SM-F18

Tire Size	PR	TT/TL	Load/Speed Index		Rims		Inflated Dimensions		Inflation Pressure (psi/bar)	Load index										Loading Applications in Free Rolling		Loading Applications in Drive Wheel					
			Free Rolling	Drive Wheel	Recom (inch)	Permitted (inch)	Section Width (mm)	Outer Diameter (mm)		Free Rolling (kg)					Drive Wheel (kg)					High Load Variation (HLV)		High Load Variation (HLV)					
										10 km/h	25 km/h	30 km/h	40 km/h	50 km/h	10 km/h	25 km/h	30 km/h	40 km/h	50 km/h	25 km/h	40 km/h	25 km/h	40 km/h	25 km/h	40 km/h		
125/80-15.3	12 RF	TL	141/A8	-	9.00	-	320	845	46/3.2	3245	2760	2595	2315	2085	-	-	-	-	-	3680	62	3090	62	-	-	-	-
									50/3.4	3425	2910	2740	2445	2200	-	-	-	-	-								
									54/3.7	3605	3065	2885	2575	2320	-	-	-	-	-								
	16	TL	144/A8	-	9.00	-	320	845	61/4.2	3725	3165	2980	2660	2395	-	-	-	-	-	3995	82	3360	82	-	-	-	-
									65/4.5	3800	3232	3040	2715	2445	-	-	-	-	-								
									71/4.9	3920	3330	3135	2800	2520	-	-	-	-	-								
400/60-15.5	14	TL	145/A8	-	AG 13.00	-	404	874	46/3.2	3735	3175	2990	2670	2400	-	-	-	-	-	4140	60	3480	60	-	-	-	-
									49/3.4	3890	3310	3120	2785	2505	-	-	-	-	-								
									52/3.6	4060	3450	3250	2900	2610	-	-	-	-	-								
	16	TL	153/A6	149/A6	AG 13.00	-	404	874	62/4.3	4475	3710	3460	3120	-	3980	3300	3085	2780	-	4685	85	3940	85	4970	85	4180	85
									67/4.6	4565	3790	3540	3185	-	4065	3375	3150	2835	-								
									75/5.2	4710	3905	3650	3285	-	4190	3475	3250	2925	-								
									78/5.4	4580	3815	3480	3210	-	4095	3395	3175	2920	-								
	18	TL	155/A6	151/A6	AG 13.00	-	404	874	84/5.8	4675	3895	3555	3280	-	4270	3540	3310	3050	-	4145	103	3785	103	4975	103	4540	103
									90/6.2	4975	4145	3785	3490	-	4450	3690	3450	3175	-								
500/60-22.5	16	TL	163 A8/159 B	151 A8/148 B	AG 16.00	15.00, 16.00, 17.00	503	1172	38/2.6	6140	5220	4915	4390	3950	4590	3900	3670	3275	2950	5800	50	4875	50	6960	50	5850	50
									41/2.8	6620	5625	5295	4730	4255	4685	3980	3750	3345	3010								
									44/3.0	6825	5800	5460	4875	4390	4830	4105	3685	3450	3105								
550/60-22.5	16	TL	167 A8/163 B	154 A8/150 B	AG 16.00	-	537	1232	35/2.4	6715	5705	5370	4795	4315	4990	4240	3990	3560	3205	6485	47	5450	47	7780	47	6540	47
									38/2.6	7170	6095	5740	5120	4610	5090	4330	4075	3640	3275								
									41/2.8	7630	6485	6105	5450	4905	5250	4460	4200	3750	3375								
600/50-22.5	16	TL	165 A8/161 B	153 A8/149 B	AG 20.00	-	611	1172	32/2.2	6345	5395	5075	4530	4080	4855	4125	3885	3465	3120	6130	43	5150	43	7355	43	6180	43
									35/2.4	6780	5760	5420	4840	4355	4955	4215	3965	3540	3185								
									38/2.6	7210	6130	5770	5150	4635	5110	4345	4090	3650	3285								

*Load capacity on recommended speed and pressure is stated with dark colour.

RF: REINFORCED

Incase full weight of vehicle is twice its empty weight or higher HLV application should be preferred.

For HLV application, the air pressure should be increased by taking normal use pressure into account. For application values other than the ones on the chart, please refer to your sales representative.

The distance should not exceed 1 km in HLV applications. For longer distances and faster speeds, please refer to your sales representative.

Special tread compound provides resistance against cuts.

DESCRIPTION

* For load capacity on various speed ratings, and inflation figures, please consult your sales representative.

** Load capacity on standard speed and weight

- Our company is entitled to make any change on any information in this catalogue, without further notice.
- This catalogue annuls all the previous catalogues
- All figures are for reference; our company is not responsible for printing errors.



ST-FLOT

Flotation **STEEL BELT**

PERFORMANCE INFORMATION

Flotation radial tyre designed to be used in agricultural vehicles, spreaders, tankers and trailers.



FEATURES

Technical Highlights

Superior performance with wide footprint and optimized tread depth, without sinking on the soil and without damaging the crop.

With its special pattern, it is suitable for use both on the traction and trailer axle.

Self-cleaning

It offers self-cleaning feature with its wide groove openings.

SIZES 560/45 R22.5 · 560/60 R22.5 · 600/55 R26.5 · 650/55 R26.5 · 710/50 R26.5

Flotation · Characteristics of **ST-FLOT**

Tire Size	TT/TL	Load/Speed Index	Rims		Inflated Dimensions (No Load)		Inflated Dimensions (W/Load)		Inflation Pressure (psi/bar)	Load capacity per tire, kg					
			Recom (inch)	Permitted (inch)	Section Width (mm)	Outer Diameter (mm)	Outer Diameter (mm)	Section Width (mm)		Speed, km/h					
										10	25	30	40	50	65
560/60 R22.5	TL	165 D	AG16.00	AG16.00, 16.00 17.00 AG20.00	564	1244	3700	558	17 / 1,2	3520	3090	2955	2660	2370	1960
									20 / 1,4	3890	3415	3265	2940	2620	2165
									23 / 1,6	4265	3740	3575	3220	2865	2370
									26 / 1,8	4500	3945	3770	3395	3020	2500
									29 / 2,0	4730	4150	3965	3570	3180	2630
									32 / 2,2	5100	4475	4280	3850	3430	2835
									35 / 2,4	5470	4800	4590	4130	3675	3040
									38 / 2,6	5840	5125	4900	4410	3925	3245
									41 / 2,8	6210	5450	5210	4690	4175	3450
									44 / 3,0	6600	5790	5535	4985	4435	3670
									46 / 3,2	6860	6020	5750	5180	4610	3810
									49 / 3,4	7185	6300	6025	5425	4830	3990
									52 / 3,6	7510	6590	6300	5670	5045	4170
58 / 4,0	8250	7240	6920	6230	5540	4580									
73 / 5,0	9270	8135	7775	7000	6230	5150									
560/45 R22.5	TL	152 D	AG16.00	AG16.00, 18.00	490	1076	3190	490	15 / 1,0	2455	2245	2145	1930	1720	1420
									20 / 1,4	2915	2665	2545	2290	2040	1685
									23 / 1,6	3380	3085	2950	2655	2360	1950
									26 / 1,8	3595	3280	3135	2825	2510	2075
									29 / 2,0	3810	3480	3320	2995	2660	2200
									32 / 2,2	4055	3705	3535	3190	2830	2340
									35 / 2,4	4300	3930	3750	3380	3005	2485
									38 / 2,6	4485	4095	3910	3525	3135	2590
									41 / 2,8	4670	4260	4070	3670	3265	2700
									44 / 3,0	4880	4460	4260	3840	3415	2820
									46 / 3,2	5095	4660	4450	4010	3565	2945
									49 / 3,4	5340	4880	4665	4200	3740	3085
									52 / 3,6	5590	5105	4880	4395	3910	3230
58 / 4,0	6140	5610	5360	4830	4295	3550									

Load capacity on recommended speed and pressure is stated with dark colour.

DESCRIPTION

- * For load capacity on various speed ratings, and inflation figures, please consult your sales representative.
- ** Load capacity on standard speed and weight

- Our company is entitled to make any change on any information in this catalogue, without further notice.
- This catalogue annuls all the previous catalogues
- All figures are for reference; our company is not responsible for printing errors.

Flotation · Characteristics of **ST-FLOT**

Tire Size	TT/TL	Load/Speed Index	Rims		Inflated Dimensions (No Load)		Inflated Dimensions (W/Load)		Inflation Pressure (psi/bar)	Load capacity per tire, kg					
			Recom (inch)	Permitted (inch)	Section Width (mm)	Outer Diameter (mm)	Outer Diameter (mm)	Section Width (mm)		Speed, km/h					
										10	25	30	40	50	65
600/55 R26.5	TL	165 D	AG20.00	AG20.00, 18.00	591	1333	3960	600	15 / 1,0	3560	3255	3110	2800	2490	2060
									20 / 1,4	4230	3870	3690	3325	2960	2445
									23 / 1,6	4900	4480	4275	3850	3430	2830
									26 / 1,8	5210	4760	4550	4095	3645	3010
									29 / 2,0	5520	5045	4820	4340	3860	3190
									32 / 2,2	5880	5370	5130	4620	4110	3400
									35 / 2,4	6240	5700	5440	4900	4360	3605
									38 / 2,6	6505	5940	5675	5110	4550	3760
									41 / 2,8	6770	6185	5910	5320	4735	3915
									44 / 3,0	7080	6470	6180	5570	4950	4095
									46 / 3,2	7395	6755	6450	5815	5170	4275
									49 / 3,4	7745	7080	6760	6095	5420	4480
52 / 3,6	8100	7405	7075	6375	5670	4685									
								58 / 4,0	8910	8140	7775	7005	6230	5150	
650/55 R26.5	TL	169 D	AG20.00	AG20.00	645	1389	4120	630	15 / 1,0	4015	3660	3500	3150	2810	2320
									20 / 1,4	4770	4350	4160	3745	3335	2755
									23 / 1,6	5520	5040	4820	4340	3860	3190
									26 / 1,8	5870	5360	5125	4615	4105	3395
									29 / 2,0	6220	5680	5430	4890	4350	3600
									32 / 2,2	6620	6045	5780	5200	4630	3830
									35 / 2,4	7025	6410	6130	5520	4915	4060
									38 / 2,6	7330	6685	6395	5760	5125	4265
									41 / 2,8	7630	6960	6660	6000	5335	4410
									44 / 3,0	7980	7280	6965	6275	5580	4610
									46 / 3,2	8330	7600	7270	6550	5830	4815
									49 / 3,4	8730	7970	7620	6865	6110	5050
52 / 3,6	9130	8335	7970	7180	6390	5280									
								58 / 4,0	10035	9160	8760	7890	7020	5800	

Load capacity on recommended speed and pressure is stated with dark colour.

DESCRIPTION

* For load capacity on various speed ratings, and inflation figures, please consult your sales representative.

** Load capacity on standard speed and weight

- Our company is entitled to make any change on any information in this catalogue, without further notice.
- This catalogue annuls all the previous catalogues
- All figures are for reference; our company is not responsible for printing errors.

Flotation · Characteristics of **ST-FLOT**

Tire Size	TT/TL	Load/Speed Index	Rims		Inflated Dimensions (No Load)		Inflated Dimensions (W/Load)		Inflation Pressure (psi/bar)	Load capacity per tire, kg					
			Recom (inch)	Permitted (inch)	Section Width (mm)	Outer Diameter (mm)	Outer Diameter (mm)	Section Width (mm)		Speed, km/h					
										10	25	30	40	50	65
710/50 R26.5	TL	170 D	AG20.00	AG20.00 AG24.00	706	1383	4100	630	15 / 1,0	4150	3790	3620	3265	2900	2400
									20 / 1,4	4930	4500	4300	3880	3445	2850
									23 / 1,6	5710	5210	4980	4490	3990	3300
									26 / 1,8	6070	5545	5300	4775	4245	3510
									29 / 2,0	6435	5880	5620	5060	4500	3720
									32 / 2,2	6850	6260	5980	5385	4790	3960
									35 / 2,4	7270	6640	6340	5710	5080	4200
									38 / 2,6	7580	6920	6610	5955	5300	4380
									41 / 2,8	7890	7200	6885	6200	5520	4560
									44 / 3,0	8250	7535	7200	6485	5770	4770
									46 / 3,2	8615	7870	7520	6770	6025	4980
									49 / 3,4	9030	8250	7880	7100	6320	5220
									52 / 3,6	9445	8630	8245	7425	6610	5460
58 / 4,0	10380	9480	9060	8160	7260	6000									

Load capacity on recommended speed and pressure is stated with dark colour.

DESCRIPTION

* For load capacity on various speed ratings, and inflation figures, please consult your sales representative.

** Load capacity on standard speed and weight

- Our company is entitled to make any change on any information in this catalogue, without further notice.
- This catalogue annuls all the previous catalogues
- All figures are for reference; our company is not responsible for printing errors.





ST-HAUL **STEEL BELT** Flotation

■ PERFORMANCE INFORMATION

Flotation radial tyre designed to be used in agricultural vehicles, spreaders, tankers and trailers.



■ FEATURES

Technical Highlights

Superior performance on dry, wet and snowy roads with optimized footprint and tread depth.

It offers superior control and low rolling resistance on all kinds of roads with its special non-directional block pattern.

Aquaplaning resistance

Frequent grooves increase aquaplaning resistance. It helps to keep the contact between the tire and the road by evacuating the water on wet ground.

■ SIZES 560/60 R22.5

Flotation · Characteristics of **ST-HAUL**

Tire Size	TT/TL	Load/Speed Index	Rims		Inflated Dimensions (No Load)		Inflated Dimensions (W/Load)		Inflation Pressure (psi/bar)	Load capacity per tire, kg						
			Recom (inch)	Permitted (inch)	Section Width (mm)	Outer Diameter (mm)	Outer Diameter (mm)	Section Width (mm)		Speed, km/h						
										10	25	30	40	50	65	70
560/60 R22.5	TL	165 D/162 E	AG16.00	AG16.00, 16.00, 17.00, AG20.00	564	1244	3700	558	17 / 1,2	3520	3090	2955	2660	2370	1960	1805
									20 / 1,4	3890	3415	3265	2940	2620	2165	1995
									23 / 1,6	4265	3740	3575	3220	2865	2370	2185
									26 / 1,8	4500	3945	3770	3395	3020	2500	2300
									29 / 2,0	4730	4150	3965	3570	3180	2630	2420
									32 / 2,2	5100	4475	4280	3850	3430	2835	2610
									35 / 2,4	5470	4800	4590	4130	3675	3040	2800
									38 / 2,6	5840	5125	4900	4410	3925	3245	2990
									41 / 2,8	6210	5450	5210	4690	4175	3450	3180
									44 / 3,0	6600	5790	5535	4985	4435	3670	3380
									46 / 3,2	6860	6020	5750	5180	4610	3810	3515
									49 / 3,4	7185	6300	6025	5425	4830	3990	3680
									52 / 3,6	7510	6590	6300	5670	5045	4170	3850
									58 / 4,0	8250	7240	6920	6230	5540	4580	4230
73 / 5,0	9270	8135	7775	7000	6230	5150	4750									

Load capacity on recommended speed and pressure is stated with dark colour.

DESCRIPTION

* For load capacity on various speed ratings, and inflation figures, please consult your sales representative.

** Load capacity on standard speed and weight

- Our company is entitled to make any change on any information in this catalogue, without further notice.
- This catalogue annuls all the previous catalogues
- All figures are for reference; our company is not responsible for printing errors.





SMT-08 Forestry

■ PERFORMANCE INFORMATION

General purpose forestry tire.



■ FEATURES

Long life

Reinforced sidewall compound improves resistance against side impacts.

High traction

Absorbs side impacts with its special sidewall compound and grips the soil perfectly, preventing slides to sides.

Perfect load capacity / Ultimate performance

Non-aggressive pattern is designed to ensure perfect balance with excellent grip on even the softest terrains and offer larger footprint to minimize soil compaction.

Strong tread and shoulder structure enable high load capacity.

■ SIZES

 500/60-22.5 · 550/60-22.5 · 600/50-22.5



Forestry · Characteristics of **SMT-08**

Tire Size	PR	TT/TL	Load/Speed Index		Rims		Inflated Dimensions		Inflation Pressure (psi/bar)	Load index										Loading Applications in Free Rolling		Loading Applications in Drive Wheel					
			Free Rolling	Drive Wheel	Recom (inch)	Permitted (inch)	Section Width (mm)	Outer Diameter (mm)		Free Rolling (kg)					Drive Wheel (kg)					High Load Variation (HLV)		High Load Variation (HLV)					
										10 km/h	25 km/h	30 km/h	40 km/h	50 km/h	10 km/h	25 km/h	30 km/h	40 km/h	50 km/h	25 km/h	40 km/h	25 km/h	40 km/h				
			Load Capacity (kg)	Inflation Pressure (kg)	Load Capacity (kg)	Inflation Pressure (kg)	Load Capacity (kg)	Inflation Pressure (kg)		Load Capacity (kg)	Inflation Pressure (kg)	Load Capacity (kg)	Inflation Pressure (kg)	Load Capacity (kg)	Inflation Pressure (kg)	Load Capacity (kg)	Inflation Pressure (kg)	Load Capacity (kg)	Inflation Pressure (kg)								
500/60-22.5	16	TL	159/A8	147/A8	AG 16.00	15.00, 16.00, 17.00	503	1172	38/2.6	5510	4685	4410	3935	3540	4090	3475	3270	2920	2630	6245	50	5250	50	5235	50	4395	50
										5940	5050	4750	4245	3820	4175	3550	3340	2980	2685								
										6125	5205	4900	4375	3940	4305	3660	3445	3075	2765								
550/60-22.5	16	TL	167/A8	155/A8	16.00	AG 16.00	537	1232	35/2.4	6715	5705	5370	4795	4315	5150	4380	4120	3680	3310	7780	47	6540	47	6590	47	5540	47
										7170	6095	5740	5120	4610	5260	4470	4210	3760	3380								
										7630	6485	6105	5450	4905	5425	4610	4340	3875	3485								
600/50-22.5	16	TL	156/A8	144/A8	AG 20.00	-	611	1172	32/2.2	4930	4190	3940	3520	3170	3725	3165	2980	2660	2395	5710	43	4800	43	4760	43	4005	43
										5265	4475	4210	3760	3385	3800	3230	3040	2715	2445								
										5600	4760	4480	4000	3600	3920	3330	3135	2800	2520								

Incase full weight of vehicle is twice its empty weight or higher HLV application should be preferred.

For HLV application, the air pressure should be increased by taking normal use pressure into account. For application values other than the ones on the chart, please refer to your sales representative.

The distance should not exceed 1 km in HLV applications. For longer distances and faster speeds, please refer to your sales representative.

Special tread compound provides resistance against cuts.

DESCRIPTION

* For load capacity on various speed ratings, and inflation figures, please consult your sales representative.

** Load capacity on standard speed and weight

- Our company is entitled to make any change on any information in this catalogue, without further notice.
- This catalogue annuls all the previous catalogues
- All figures are for reference; our company is not responsible for printing errors.





SMT-18 Forestry

■ PERFORMANCE INFORMATION

General purpose forestry tire.



■ FEATURES

Long life

Special sidewall compound protects the tire by effectively absorbing side impacts.

Perfect load capacity / Ultimate performance

Non-aggressive pattern is designed to ensure perfect balance with excellent grip on even the softest terrains and offer larger footprint which to minimize soil compaction and protect the crops.

Reinforced tread and shoulder compound along with durable carcass structure enable high load capacity and improve durability for tough forest conditions.

■ **SIZES** 400/60-15.5 · 500/60-22.5 · 550/60-22.5 · 600/50-22.5

Forestry · Characteristics of SMT-18

Tire Size	PR	TT/TL	Load/Speed Index		Rims		Inflated Dimensions		Inflation Pressure (psi/bar)	Load index										Loading Applications in Free Rolling				Loading Applications in Drive Wheel			
			Free Rolling	Drive Wheel	Recom (inch)	Permitted (inch)	Section Width (mm)	Outer Diameter (mm)		Free Rolling (kg)					Drive Wheel (kg)					High Load Variation (HLV)		High Load Variation (HLV)					
										10 km/h	25 km/h	30 km/h	40 km/h	50 km/h	10 km/h	25 km/h	30 km/h	40 km/h	50 km/h	25 km/h	40 km/h	25 km/h	40 km/h				
			Load Capacity (kg)	Inflation Pressure (kg)	Load Capacity (kg)	Inflation Pressure (kg)	Load Capacity (kg)	Inflation Pressure (kg)		Load Capacity (kg)	Inflation Pressure (kg)	Load Capacity (kg)	Inflation Pressure (kg)	Load Capacity (kg)	Inflation Pressure (kg)	Load Capacity (kg)	Inflation Pressure (kg)	Load Capacity (kg)	Inflation Pressure (kg)								
400/60-15.5	18	TL	155/A6	151/A6	AG 13.00	-	404	874	78/5.4	4580	3815	3480	3210	-	4095	3395	3175	2920	-	4145	103	3785	103	4975	103	4540	103
									84/5.8	4675	3895	3555	3280	-	4270	3540	3310	3050	-								
									90/6.2	4975	4145	3785	3490	-	4450	3690	3450	3175	-								
500/60-22.5	16	TL	163 A8 /159 B	151 A8 /148 B	AG 16.00	15.00, 16.00, 17.00	503	1172	38/2.6	6140	5220	4915	4390	3950	4590	3900	3670	3275	2950	5800	50	4875	50	6960	50	5850	50
									41/2.8	6620	5625	5295	4730	4255	4685	3980	3750	3345	3010								
									44/3.0	6825	5800	5460	4875	4390	4830	4105	3865	3450	3105								
550/60-22.5	16	TL	167 A8 /163 B	154 A8 /150 B	16.00	AG 16.00	537	1232	35/2.4	6715	5705	5370	4795	4315	4990	4240	3990	3560	3205	6485	47	5450	47	7780	47	6540	47
									38/2.6	7170	6095	5740	5120	4610	5090	4330	4075	3640	3275								
									41/2.8	7630	6485	6105	5450	4905	5250	4460	4200	3750	3375								
600/50-22.5	16	TL	165 A8 /161 B	153 A8 /149 B	AG 20.00	-	611	1172	32/2.2	6345	5395	5075	4530	4080	4855	4125	3885	3465	3120	6130	43	5150	43	7355	43	6180	43
									35/2.4	6780	5760	5420	4840	4355	4955	4215	3965	3540	3185								
									38/2.6	7210	6130	5770	5150	4635	5110	4345	4090	3650	3285								

Incase full weight of vehicle is twice its empty weight or higher HLV application should be preferred.
 For HLV application, the air pressure should be increased by taking normal use pressure into account. For application values other than the ones on the chart, please refer to your sales representative.
 The distance should not exceed 1 km in HLV applications. For longer distances and faster speeds, please refer to your sales representative.
 Special tread compound provides resistance against cuts.

DESCRIPTION

- * For load capacity on various speed ratings, and inflation figures, please consult your sales representative.
- ** Load capacity on standard speed and weight

- Our company is entitled to make any change on any information in this catalogue, without further notice.
- This catalogue annuls all the previous catalogues
- All figures are for reference; our company is not responsible for printing errors.

RIMS

» DROP CENTRE RIM

a) 4.00E - 7 JA

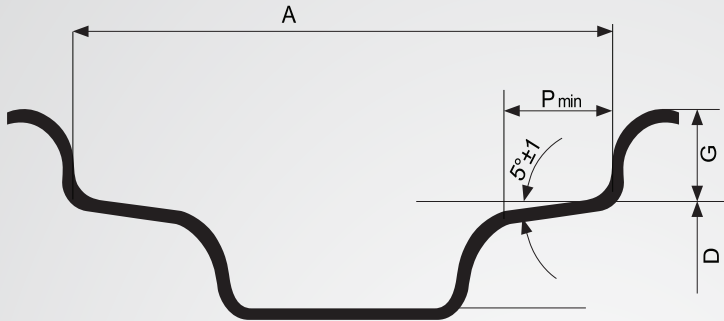

b) 9 - 16.00

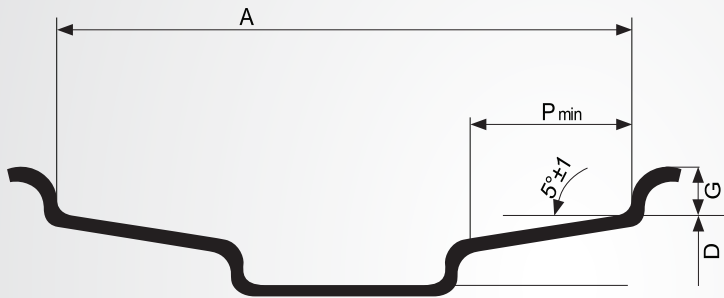

Rim	Dimensions (mm)		
	A	G ± 1	P min.
4.00E	101.5	20	18
4.50E	114.5		
5.00F	127	±2	22.5
5 JA	127		
5.50F	139.5	22.5	23.5
6.00F	152.5		
6 LB	152.5	22	25
7.00I	178		
7 JA	178	16	23
9	228.5		
9	228.5	±2.5	25.5
11	279.5		
12	305	25.5	31.5
13	330		
13.0	330	19	47
13.00	330		
14	355.5	±5	25.5
16.00	406.5		

Rim Diameters	
Nominal Rim Code ()	Rim Diameter D (mm)
8	202.4
10	253.2
12	304.0
13	329.4
14	354.8
15	380.2
15.3*	388.3
16	405.6
17	436.6
18	462
19	487.4
20	512.8
24	614.4

* For only 9.00

» DIVIDED RIM

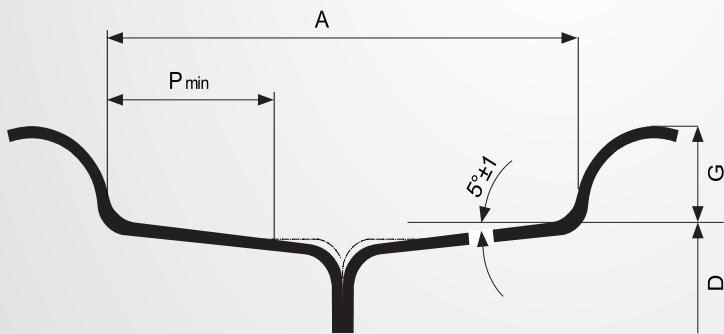

Rim	Dimensions (mm)		
	A ± 2	G ± 2	P ± 2
4.00E	101.5	20	25
5.00F	127	22.5	23.5
5.50F	139.5		

Rim Diameters	
Nominal Rim Code ()	Rim Diameter D (mm)
9	227.8
10	253.2

» 5° DROP-CENTRE RIM - DD (L) RIM CONTOUR

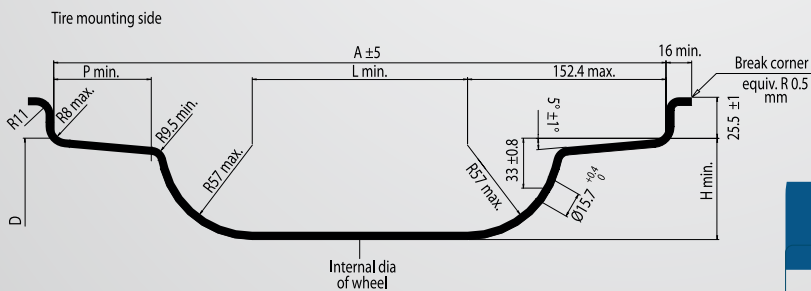

Diameters		
Nominal Diameter Code	Specified Diameter D (mm)	Internal Diameter of the wheel
34	868.4	713.3
38	970	814.9
42	1071.6	916.5
46	1173.2	1018.1

Rim Contour	Dimensions (mm)			
	Rim Width (A)	P min.	L GAGE min.	H min.
DD15L	381	36.5	134	60
DD16L	406.5	50.5	160	60
DD18L	457	50.5	160	60

» W, DW AND TW RIMS

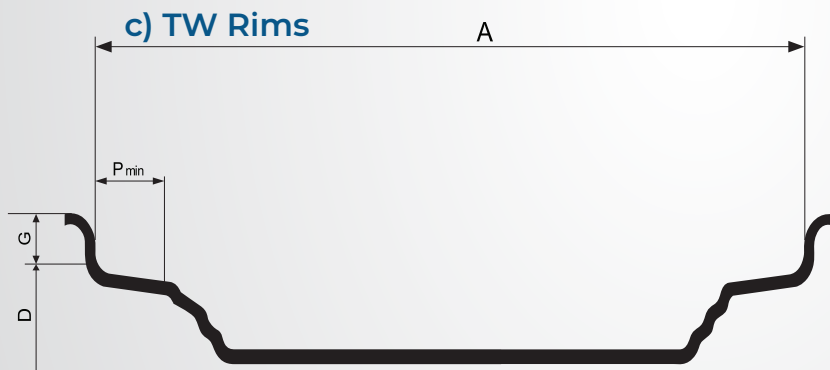
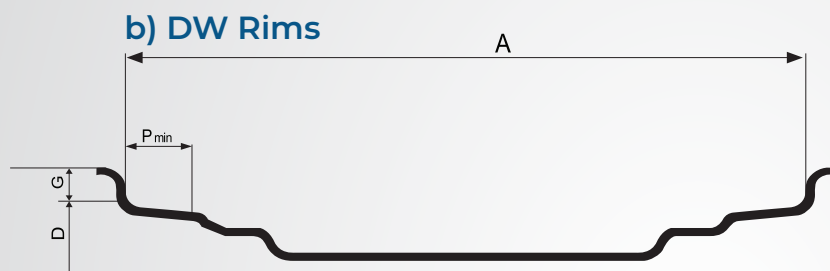
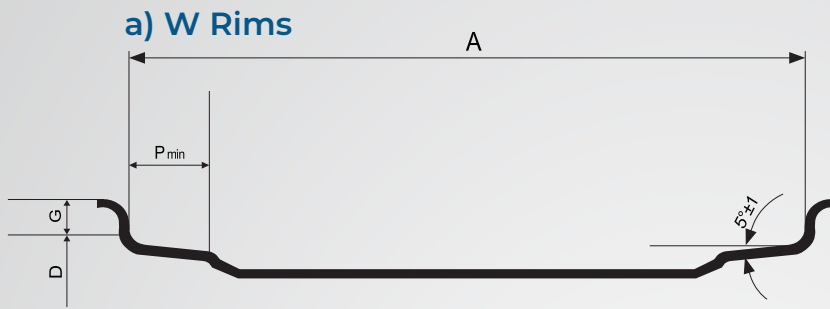

Rim Diameters	
Nominal Rim Code (*)	Rim Diameter D (mm)
16	405.6
18	462.0
20	512.8
24	614.4
26	665.2
28	716.0
30	766.8
32	817.6
34	868.4
36	919.2

Rim Diameters	
Nominal Rim Code (*)	Rim Diameter D (mm)
38	970.0
40	1020.8
42	1071.6
44	1122.4
66	1173.2
48	1224.0
50	1274.8
52	1325.6
54	1376.4

Rim	Dimensions (mm)				
	A	G ± 1	P min.		
W6	152.5	±2.5	22.5		
W7	178		23.5		
W8	203	±2.5	23		
W8	203		25.5	27	
W9	228.5				
W10	254				
W11	279.5				
W12	305				
W13	330				
W8L	203		22.5	27	
W10L	254				
W14L	355.5		±5	33	
W15L	381				
W16L	406.5				
W18L	457	±2.5	27		
DW10	254				
DW11	279.5				
DW12	305				
DW13	330				
DW13L	330				
DW14L	355.5				
DW15L	381				
DW16L	406.5			±5	50.5
DW18L	457				
DW20B*	508	±6.5	50.5		
DW21B*	533.5				
DW23B*	584				
DW24B*	609.5				
DW25B*	635				
DW27B*	686				
DW28B*	711				
DW30B*	762				
TW13	330			±2.5	27
TW14L	355.5			±5	36.5
TW15L	381				
TW16L	406.5				
TW18L	457				
TW20B	508	±6.5	50.5		
TW21B	533.5				
TW23B	584				
TW24B	609.5				
TW25B	635				
TW27B	686				
TW28B	711				
TW30B	762				

* It is mentioned as DW-A, now DW-B in current standards.

» 15° DROP-CENTRE RIMS WIDTH CODES AG CONTOUR

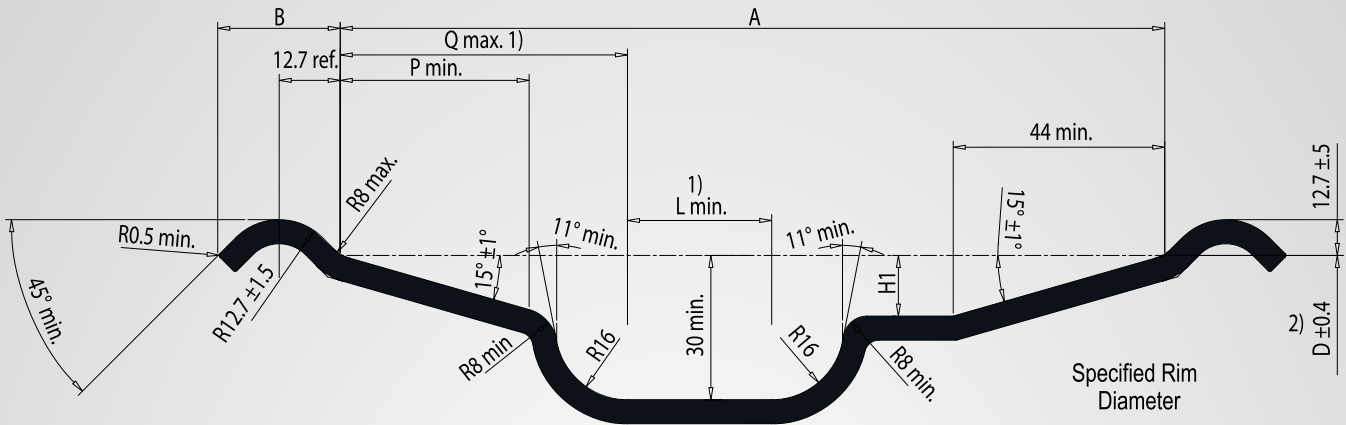

With Code	Dimensions (mm)						Nominal Diameter Code
	A ± 5	P min.	Q max.	H1 min.	B min.-max.	L min.	
AG 6.75	171.5	34	70	10	14-17	30	14.5
AG 7.50	190.5	34	70	10	19-29	30	19.5
AG 8.00	203.5	34	70	10	14-17	30	14.5 - 15.5
AG 8.25	209.5	34	70	10	18-27	30	16.5 - 19.5
AG 9.75	247.5	34	70	10	18-27	30	16.5
AG 11.75	298.5	34	70	11	19-29	50	17.5 - 19.5 - 22.5
AG 13.00	330	34	70	11	19-29	50	15.5 - 19.5 - 22.5 - 26.5
AG 14.00	355.5	34	70	11	19-29	50	19.5 - 22.5
AG 16.00	406.5	34	70	11	19-29	50	17.5 - 22.5 - 26.5
AG 20.00	508	44	70	11	19-29	50	22.5 - 24.5 - 26.5 - 30.5
AG 22.00	558.5	44	70	11	19-29	50	24.5
AG 24.00	609.5	44	70	11	19-29	50	22.5 - 24.5 - 26.5 - 30.5
AG 28.00	711	44	70	11	19-29	50	24.5 - 30.5
AG 28.00	711	44	70	11	19-29	50	30.5

Diameters			
Nominal Diameter Code	Specified Diameter D (mm)	Nominal Diameter Code	Specified Diameter D (mm)
14.5	368.3	22.5	571.5
15.5	393.7	22.5	622.3
16.5	419.1	26.5	673.1
17.5	444.5	30.5	774.7
19.5	495.3		

VALVES

» TUBELESS VALVES

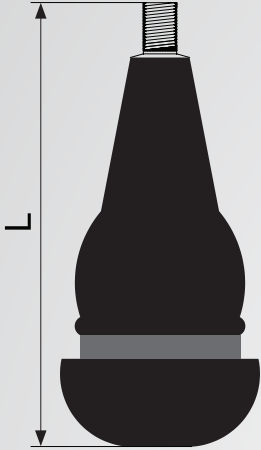

Valve Type, Reference Standard			Valve Diameter	Valve Height (L)
DIN	ETRTO	TRA		
-	V2-03-9	-	8.8	59
43 GS 11.5	V2-03-1	TR413	11.3	42.5
49 GS 11.5	V2-03-2	TR414	11.3	48.5
43 GS 16	V2-03-3	TR415	15.7	42.5

» AIR-WATER VALVE

Valve Parts	Valve Diameter	Valve Height (L)
V5.01.1 ve V4.02.1	15.7	47.5

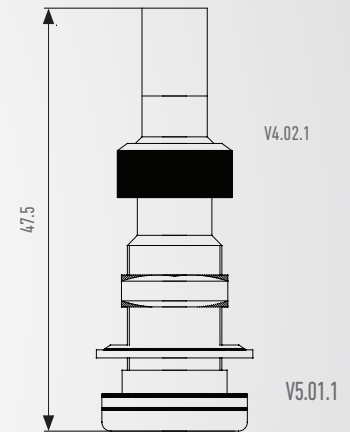

» MATCHING OF SOME VALVE PARTS

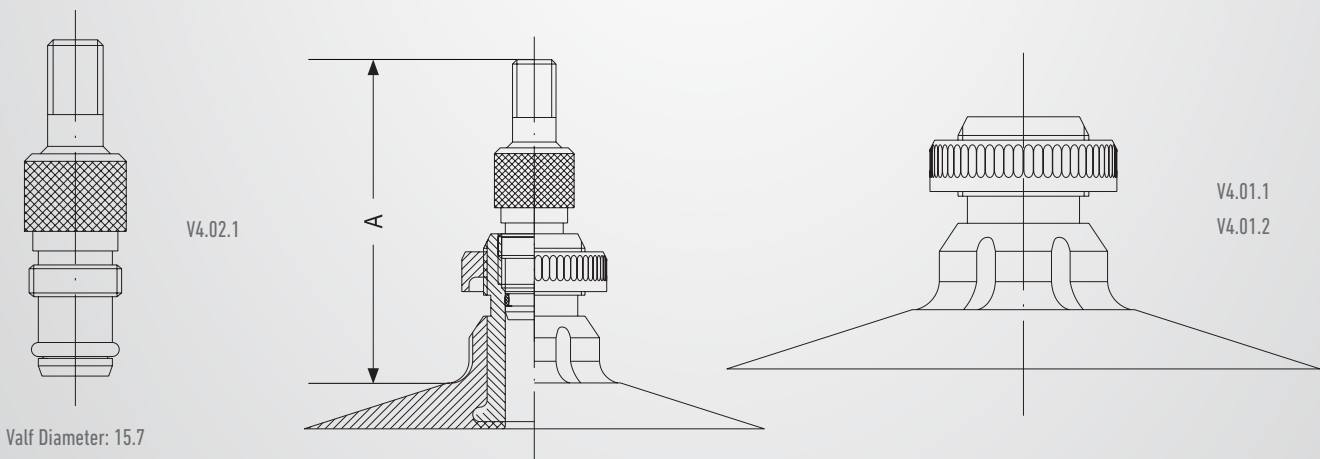

Valf Diameter: 15.7

Valve Type		Parts
V4.03.1	V4.01.1	V4.02.1
V4.03.2	V4.01.2	

	A
V4.03.1	41.15
V4.03.2	49.65

MOUNTING AND DISMOUNTING INSTRUCTIONS

- Any mistake in replacement process may cause fatal results, and it must be done at authorized service points with appropriate machinery and by trained staff.
- The rim must be clean and undamaged. Never mount a tire to a cracked, smashed, deformed or repaired/welded rim. Any material which may harm the tire such as oil, rust or dirt must be cleaned. The rim size must be within the tolerance range, recommended by manufacturer of the vehicle.
- The tire must be dry and free of external material. In the mounting process, lubricant may be applied on the bead section of the tire. Chemical substances such as petroleum based oils, silicon or detergents must not be used as lubricant. Those products may cause tire to lose its special chemical properties.
- The tire inflation air must be moisture free. After mounting the tire, centering of the tire to the rim must be verified.
- The valves must be brand new and capped. In case the new tire is tube type, a flap must be placed between the tire and the tube. The flap must be powdered before the process.
- New tire must not be matched with old ones.
- In case rotation direction or outer side were stated on the sidewall, this information must be taken into consideration.
- Any information regarding rotation direction should be taken into consideration if stated on the sidewall.

HOW TO INFLATE A TIRE?

- Keep your distance for your safety.
- Use an inflation cage, mounted to the wall or ground, if there is.
- Do not exceed recommended inflation pressure.
- Use a moisture/dirt filter at the pressurized air line to prevent any moisture/dirt inside the tire.
- Do not exceed the recommended inflation pressure during the seating of the bead. In case they do not fit, abort the process.

Incorrect inflation pressure causes following results:

- Decreases the performance of the tire and provides an unsafe and uncomfortable drive. Correct and stable inflation pressure increases the performance and life span of the tire. Inflation pressure must be checked periodically.
- Low inflation pressure decreases the grip, reduces the life span of the tire by overheating, irregular wearing and even separations/cracking at the shoulders and sidewalls. Over inflation pressure causes When the recommended inflation pressure was exceeded, the situation causes the rim to be damaged and vehicle to bounce; the durability against impacts decreases and jeopardises the human life by bursting.
- The fuel consumption increases.
- Causes irregular corrosion on tread.

STORAGE

- Tires should be stored vertically on special shelves. In case they are stored vertically one above another, maximum number of tires should not exceed 8 and they should be switched positions every month.
- In the tire storage area, there must not be any material which may create ozone effect such as oil, gasoline, solvent, car battery acid, acid installation system, sodium hydroxide, electrical engine or fluorescent light, even though the tire are already installed on the vehicle.
- The tire storage must be moisture free and must be ventilated regularly, not to cause moisture. There must not be any water in the area.
- In case there is no facility to store the tire on special shelves, their contact with the ground must be prevented and they must be stored one above the other, if they are mounted on rim or vertically, if not mounted on rim.

USE OF LIQUID BALLAST IN TRACTOR TIRES

The traction of a tire is in direct proportion to its weight. The heavier the tire is, the more traction it has.

In order to increase the traction power and to prevent wear which may occur as a result of slipping, iron cast ballasts must be installed on the front or rear side of the tractor or liquid ballast must be applied. STARMAXX and vehicle manufacturers recommend use of iron cast ballasts. In cases which iron cast ballast application is not possible, tire may be liquid filled.

- Liquid ballasting should be done by filling in the tire with a mixture of water and calcium chloride without exceeding 75% of the tire.
- Using just water without adding extra materials is only possible when there no probability of freeze. However, using only water decreases the effect of ballasting by up to %20. When antifreeze is needed, water / calcium chloride mixture should be used.

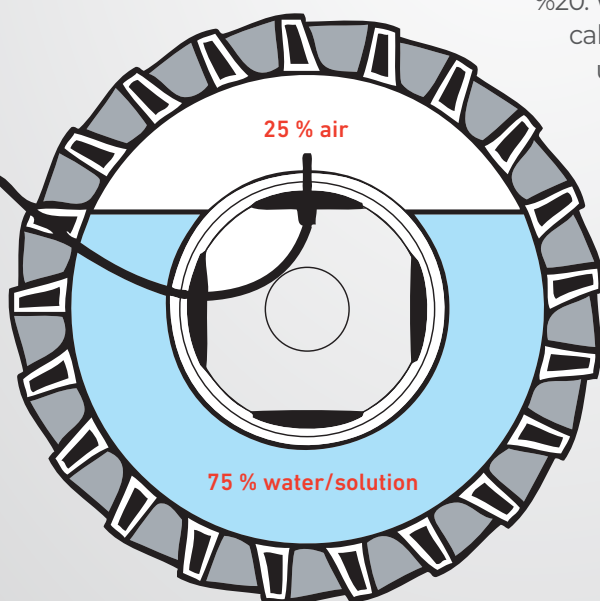

- The tire must not be filled with water completely, by any means.

LIQUID FILLING PROCESS:

- 1- Deflate the tire.
- 2- Rotate the tire in a way to position the valve at the top.
- 3- Remove the valve core.
- 4- Start filling the water according to the instructions in the manual of the pump.

- 5- During the filling process, remove the pump regularly and let the air get out of the tire.
- 6- Stop the filling process when liquid starts to flow from the valve. Mount the valve core.
- 7- Inflate the tire to its normal pressure.

Important Remark:

In tubeless tires, it is recommended to use an inner tube to prevent rim to rust.

WATER / SOLUTION BALANCING CHART (FOR ONE TIRE)

Size	Rim	Amount of Solution Required (litre)	Solution preparation	
			CaCl ₂ Amount (kg)	Total Weight (kg)
7.50 - 20	5.50 F	30	8	35
9.5 - 20	W8	35	9	41
8.3 - 24	W7	40	11	48
9.5 - 24	W8	50	13	58
11.2 - 24	W10	70	19	81
12.4 - 24	W11	80	22	93
13.6 - 24	DW12	120	32	39
14.9 - 24	W13	150	40	174
18.4 - 26	W16L	280	76	325
23.1 - 26	DW20	470	127	545
11.2 - 28	W10	90	24	104
12.4 - 28	W11	110	30	128
13.6 - 28	W12	140	38	162
14.9 - 28	W13	180	49	209
16.9 - 28	W15L	220	59	255
14.9 - 30	W13	200	54	232
16.9 - 30	W15L	250	67	290
18.4 - 30	W16L	320	86	371
12.4 - 32	W11	130	35	151
16.9 - 34	W15L	280	76	325
18.4 - 34	W16L	360	97	418
12.4 - 36	W11	150	40	174
13.6 - 36	W12	180	49	209
13.6 - 38	W12	190	51	220
14.9 - 38	W12	220	59	255
16.9 - 38	W15L	280	76	325
18.4 - 38	W16L	370	100	429
20.8 - 38	W18L	487	131	565



2025 EDITION

At Starmaxx, we create AGR tires with one goal: To keep you moving forward, no matter the challenge. Our tires blend durable design with advanced technology, tailored to endure the diverse conditions of agriculture. They're built to last and perform, providing the stability and strength needed in agriculture.

For every season and field, Starmaxx AGR tires are the reliable choice for farmers who demand both quality and value. Trust in our tires to get the job done, day in and day out.

DISTRIBUTED BY

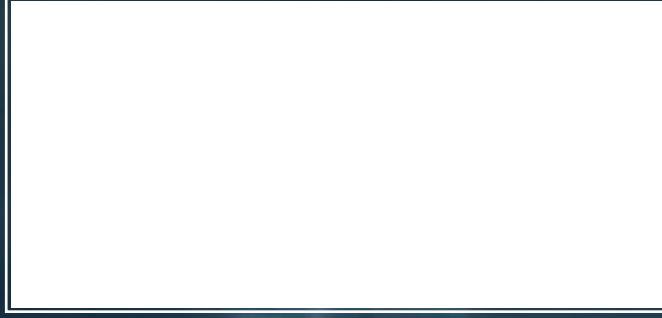

**starmaxx**
AGRICULTURAL TIRES

Headquarters - Factory

Petlas Tire Industry and Trade Kindam Mahallesi Ankara - Kayseri Caddesi No: 2/1 Kırşehir / TÜRKİYE
T: +90 386 252 65 50 • F: +90 386 252 65 70

Int. Sales & Marketing

Petlas Tire Industry and Trade Ako Kule, Söğütözü Mh. 2178. Cad. No: 6 06530 Ankara / TÜRKİYE
T: +90 312 309 30 30 • F: +90 312 309 22 66

Petlas Tire USA

1111 E. Lincolnway STE 205 Cheyenne, WY 82001 USA

www.starmaxx.com **MADE IN TÜRKİYE**